



CAN-AM

Outlander 330, 400, 450L, 500, 500L, 570, 570L
650, 800

ITEM#	QTY.	PART#	DESCRIPTION
1	1	2801-100	Bottom Mount Plate
2	2	HDW2065	5/16 x 2-3/4 x 4-1/4 Sq. U-Bolt
3	4	HDW9339	5/16 x 1-1/2 x 2-3/4 Sq. U-Bolt
4	8	HDW7058	5/16 Nylock Nut
5	8	HDW9002	5/16 Flat Washer

PART# 4501-0627

PLOW MOUNTING INSTALLATION INSTRUCTIONS

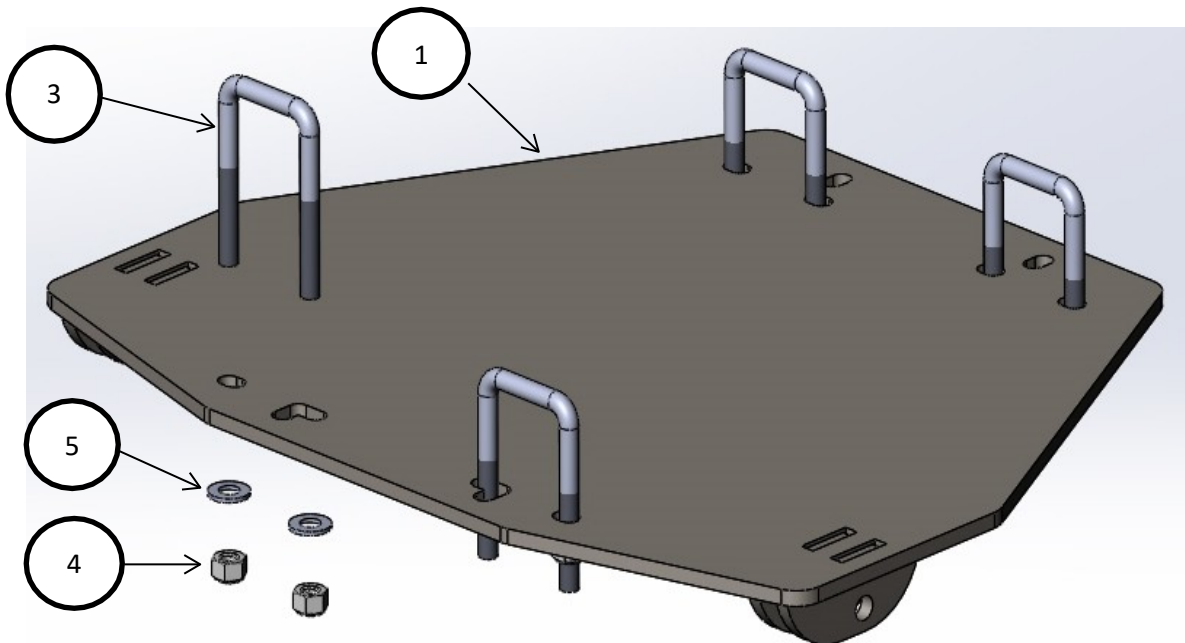
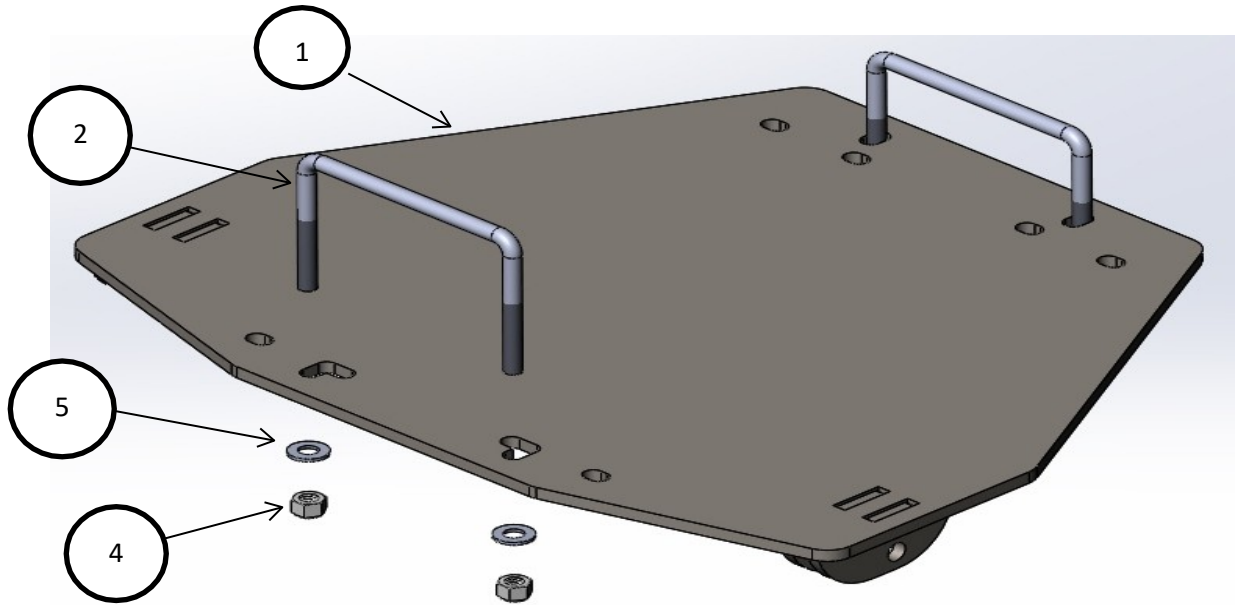

Bottom Mount Installation Instructions

For models with dual frame tubes.

1. Remove rear six bolts from the skidplate and let it hang down so you can access the frame tubes. You do NOT need to remove the large carriage bolts to remove the skidplate.
2. Place four 1-1/2" x 2-3/4" square u-bolts around the main frame tubes an inch or two in front of each footpeg support bracket per the illustration.
3. Temporarily slide the mount up into place (with the skidplate still hanging down) to make sure the u-bolts are positioned properly. The tabs on the mount go towards the front of the machine. Once positioned, remove the mount and mark the skidplate where the u-bolts will go through. Drill 3/8" holes in the skidplate for the u-bolts. Reinstall the skidplate with the pushing the u-bolts down through the drilled holes.
4. Push the bottom mount up and insert the u-bolts through the matching outer holes in the mount plate. Install the flat washers and 5/16" nylock nuts.
5. Slide the blade/push tube assembly under the ATV. Lift the rear of the assembly up and align the holes in the bottom mount tabs and the push tube and install the wire loop pins.

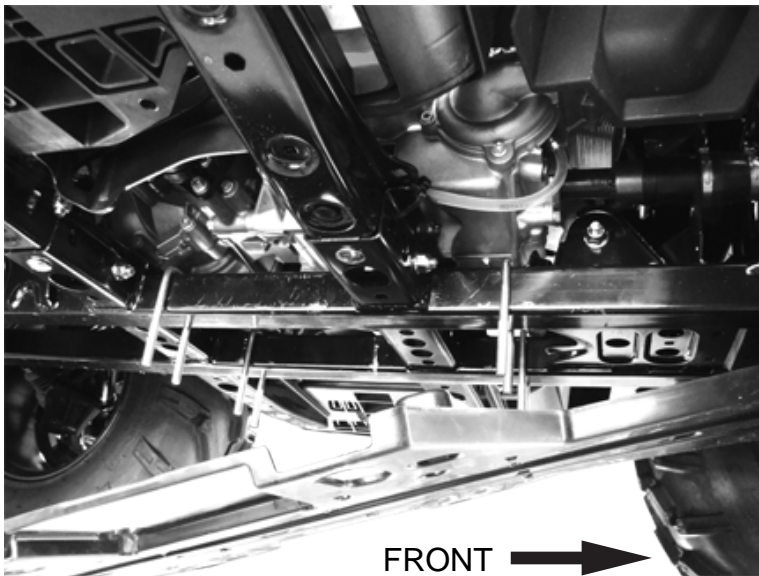

#1. Remove rear skidplate bolts and let it hang down. Hang u-bolts over the main frame tubes.

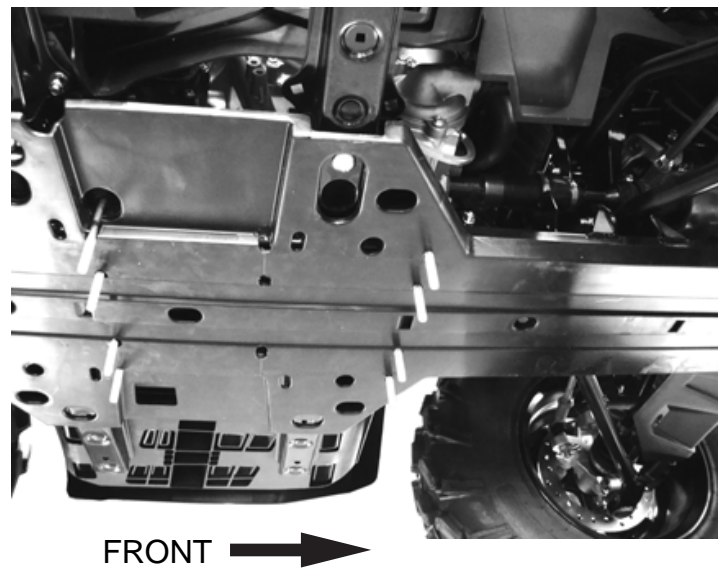

#2. Drill holes in the skidplate and reinstall with the u-bolts hanging through.

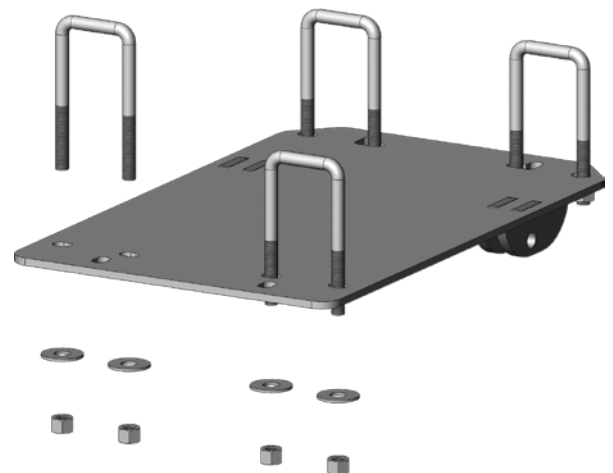
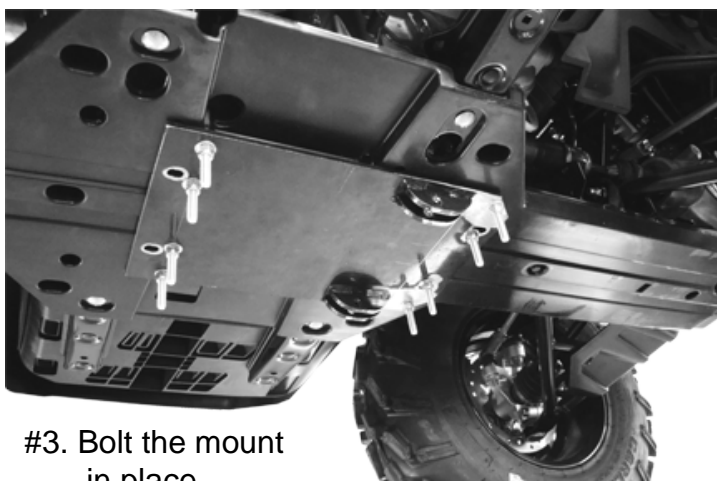

Bottom Mount Installation Instructions

For models with single rectangular frame tube.

1. Remove the skidplate where applicable. You can remove it permanently or mark and drill holes for the u-bolts to drop through.
2. Place the two 2-3/4" x 4-1/4" u-bolts around the frame tubes per the illustration. Caution: Do not pinch the brake line.
3. Push the bottom mount up and insert the u-bolts through the center holes. Note: The tabs on the bottom mount are placed towards the front of the mount. Install the flatwashers and nylock nuts. Push back until the rear u-bolt hits the back footpeg support tube. Tighten the nylock nuts.
4. Slide the blade/push tube assembly under the bottom mount tabs and push the tabs on the push tube up into the bottom mount and install the wire loop pins.

