



RM4 PLOW MOUNT INSTRUCTIONS

07-158 YAMAHA GRIZZLY 500/700

PART# 4501-0773

ITEM	QTY.	PART#	DESCRIPTION
1	1	2597-100	Plow Mount
2	1	KD100	Removable Mount
3	2	HDW7078	Pre-Assembled in Push Tube
4	2	HDW9110	Pre-Assembled in Push Tube
5	1	HDW9185	1/2" Cotterless Hitch Pin
6	2	HDW9189	1/4 x 1-1/2 Carriage Bolt
7	2	HDW7050	1/4 Nylock Nut
8	6	HDW9002	5/16 Flat Washer
9	2	HDW1050	8mm x 20mm Hex Bolt
10	4	HDW7058	5/16 Nylock Nut
11	2	HDW2049	5/16 x 1-1/4 x 1-3/4 Rd. U-Bolt

1. Remove the front lower plastic skidplate. If you already have a winch installed, you may need to unbolt the winch mount to ease the installation of the RM4 mount and carriage bolts.
2. The RM4 permanent mount (#1) will install with the top channel over the existing horizontal lower bumper tube. The lower holes in the mount will line up with the end of the main frame tubes. The frame tubes are threaded for 8mm bolts. The upper holes in the mount are for clamping the u-bolts around the main frame tubes. See illustration on back page.
3. Bolt the bottom of the mount in place using the two 8mm x 20mm hex bolts (#9) AND 5/16" flat washers (#8). Bolt the upper channel of the RM4 mount around the horizontal bumper tube using two 1/4" x 1-1/2" carriage bolts (#6). Secure with two 1/4" nylock nuts (#7).
4. Slide the two 5/16" u-bolts (#11) around the main frame tubes and out through the upper holes in the RM4 mount. Secure with four 5/16" flat washers (#8) and four 5/16" nylock nuts (#10).
5. Reinstall your winch if previously unbolted.
6. You will need to trim the plastic skidplate for clearance with the RM4. Hold the skidplate in place and mark the area that will be trimmed out for the mount and receiver to fit. See illustration on back page. Use a sharp knife, hacksaw or other cutting tool to cut out the skidplate. Put the skidplate back in place.
7. Once the plow mount is installed, you should hook up the push tube and blade assembly and adjust the droop stop bolts. There should be a 1/4" to 1/2" gap between bolt head and removable mount. On some older models, the bolts may be in the removable mount. On new style, they are in the push tubes. These bolts stop the plow from rolling under the machine and/or lifting the front of the machine off the ground. These bolts must be adjusted properly for the correct amount of float or may cause damage to your machine or plow.

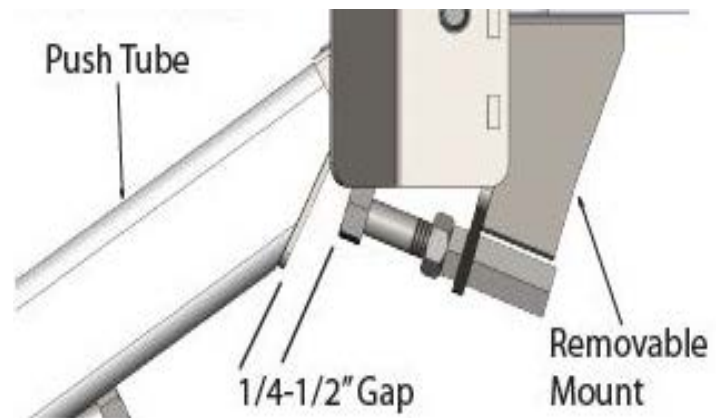

FOR QUESTIONS OR COMMENTS PLEASE CALL: 320-964-1616 (7:00 to 4:30 CST Monday through Thursday).

INST2597PF-1

RM4 Plow Mount Installation Instructions

Yamaha Grizzly 550/700

PART# 4501-0773

Page 2

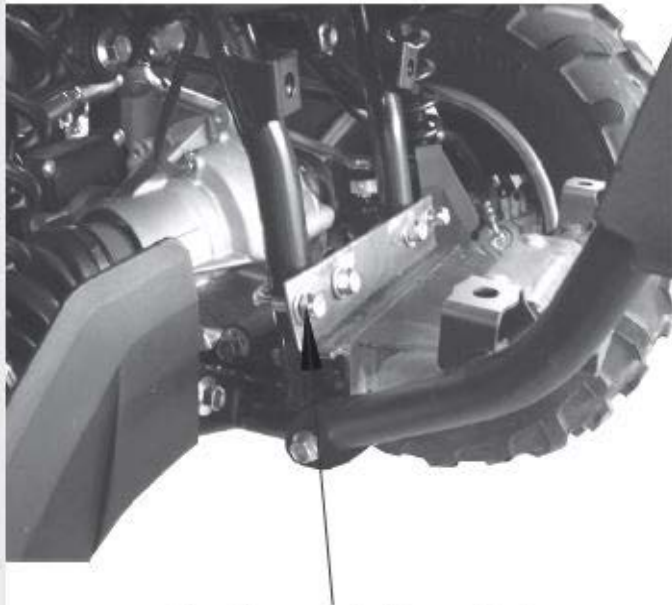
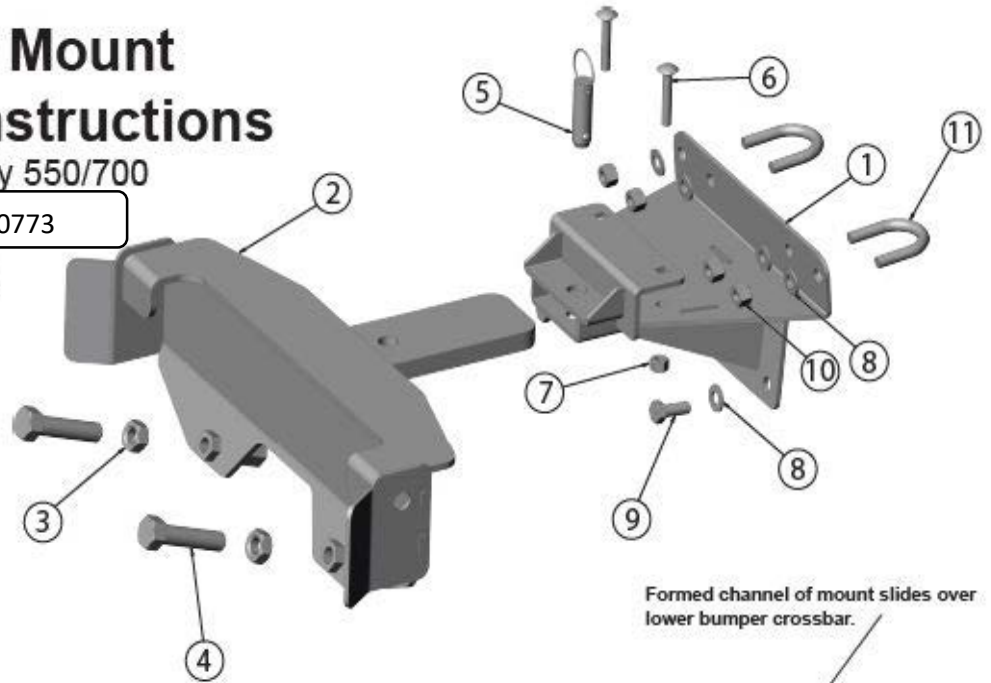

Clamp the upper part of the mount in place using the supplied U-bolts around the main frame tubes.

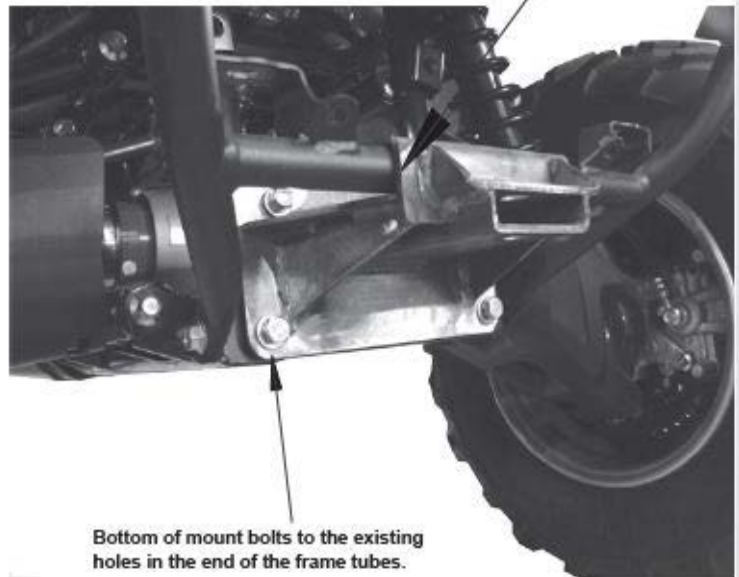

Bottom of mount bolts to the existing holes in the end of the frame tubes.

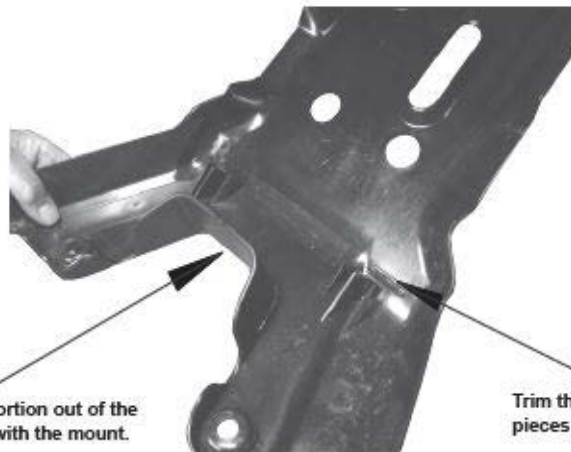

Trim the raised center portion out of the skidplate for clearance with the mount.

Trim these raised plastic pieces off the skidplate.

FOR QUESTIONS OR COMMENTS PLEASE CALL: 320-964-1616 (7:00 to 4:30 CST Monday through Thursday).

INST2597PF-2

