

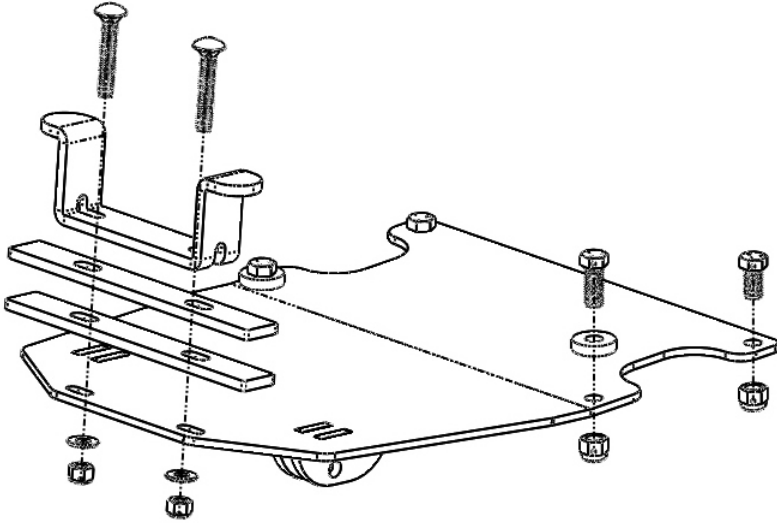

MOOSE PLOW BOTTOM MOUNT INSTRUCTIONS  
2017 POLARIS RANGER DIESEL HST

PART# 4501-0583



QTY.	PART#	DESCRIPTION
1	2820-200	Plow Mount Weldment
1	2820-2	Hanger Bracket
2	2820-3	Spacer Block
2	FG2741	Spacer 1 x 1/4
2	HDW2106	3/8 x 3/4 Hex Bolt
2	HDW7058	5/16 Nylock Nut
2	HDW9002	5/16 Flat Washer
2	HDW2067	5/16 x 2 Carriage Bolt
4	HDW7061	3/8 Nylock Nut
2	HDW2100	3/8 x 1 Hex Bolt

Remove skid plate if needed. Leaving skid plate on will require marking and drilling hole in plate to bolt up.

Hole mount up in place with the end with the notches going toward the front and match up to arm location. On the very front use the 3/8 x 3/4 hex bolts and nylock nuts to mount this part do not tighten at this time.

Now lift up mount plate and place second set of bolt in place as shown using the 3/8 x 1 hex bolts and nylock nuts. Make sure you use the FG2741 spacers to go between the mount and machine. Do not tighten yet.

Lift rear of mount up in place and now slide the hanger bracket up between the frame tubes as shown. Place the two spacer block on top of the mount plate so they go between the mount and hanger bracket, lift up and place the two 5/16 x 2 carriage bolt down through the hanger bracket spacer block and the mount plate and secure with the 5/16 nylock nuts.

Align the mount and tighten all hardware.

Question or Comments Please Call 763-689-4800

INST2820

