

# INSTALLATION INSTRUCTIONS

## DRAG SPECIALTIES ELECTRONIC SPEEDOMETER P/N 2210-0104

**ATTENTION INSTALLER** (if other than owner): Please forward this Instruction Sheet to the purchaser of this product. These instructions contain valuable information necessary to the end user.

**INTRODUCTION:** These instructions describe the procedure for properly installing the replacement electronic speedometer in 96-03 Softails, Dyna Wide Glides, and Road Kings.

Review instructions carefully before beginning, as they contain important information. Please retain for future reference. Particularly important information is distinguished in these instructions by the following notations:

**NOTE: A NOTE** provides key information to make procedures easier or clearer.

**CAUTION: A CAUTION** indicates special procedures that must be followed to avoid damage to the motorcycle and/or accessories.

**WARNING!: A WARNING** indicates special procedures that must be followed to avoid injury to a motorcycle operator or person inspecting or repairing the motorcycle.



**NOTE:** These three wires should be color-coded with one being orange/white, one white/green, and one black.

**NOTE:** The installation of this speedometer head will require a sub wire harness on most models. Please use the sub wire harnesses listed below for the appropriate model:

96-98 Softail models	<b>PART #2120-0250</b>
99-03 Softail models	Not required
96-97 FXDWG models	<b>PART #2120-0294</b>
98 FXDWG models	<b>PART #2120-0295</b>
99-03 FXDWG models	Not required
96-97 FLHR models	<b>PART #2120-0302</b>
98 FLHR models	<b>PART #2120-0303</b>
99-03 FLHR models	Not required

### PROCEDURE:

**WARNING!:** Disconnect the battery by first removing the negative battery cable.

#### 96-98 SOFTAIL MODELS:

**NOTE:** Installation of this later version of speedometer head onto 96-98 Softail models will require the use of a sub wire harness, Drag Specialties **PART #2120-0250**.

1. Remove the instrument panel nut and lift panel from tank. Disconnect the 12-pin connector to the speedometer and also the connector at the ignition switch and remove the dash panel from the bike.
2. Remove the speedometer trip reset switch from the dash panel.
3. Disconnect the three-wire connection going to the speedometer sensor in the transmission.
4. On the back of the original speedometer, you will find that there are three wires from the speedometer to the 12-pin connector. Either remove these three wires from the connector, or cut them to separate the speedometer from the 12-pin connector.

5. If you cut the wires, tape them off so there is no chance of any wire shorting out.
6. Remove the speedometer head by releasing the three latches under the speedometer and removing the speedometer head through the top of the dash panel.
7. Install the original rubber gasket from the old speedometer onto the new speedometer and install the new speedometer into the dash panel. Make sure all three latches are secure.
8. Install the **PART #2120-0250** sub wire harness in between the two original wire harness connectors. Make sure that both connectors are fully seated and locked.
9. Install the new reset switch into the dash housing.
10. Plug the new 12-pin connector into the mating connector on the back of the speedometer head.
11. Reconnect the ignition switch connector under the dash.
12. Connect the three-wire connector to the existing speed sensor.
13. Center the dash panel over the gas tank and install the mounting hardware to secure the dash panel.
14. Reconnect the battery cables, making sure that the negative cable is always reconnected last.
15. Check operation of the speedometer and all indicator lamps.
16. Clear diagnostic codes by doing the following steps:
17. Turn the ignition from Off to On while holding in the reset button on the dash.
18. The code "d01Clr" will be displayed; release the reset button.
19. Press the reset button again and hold button in. Code "d02Set" will be shown. Hold button in until code "d02Clr" is displayed. This indicates that the set code has been cleared. Release the reset button.
20. Exit the diagnostic mode by turning the ignition switch from On to Off to On, without holding in the reset button on the dash panel.



# INSTALLATION INSTRUCTIONS

## DRAG SPECIALTIES ELECTRONIC SPEEDOMETER P/N 2210-0104

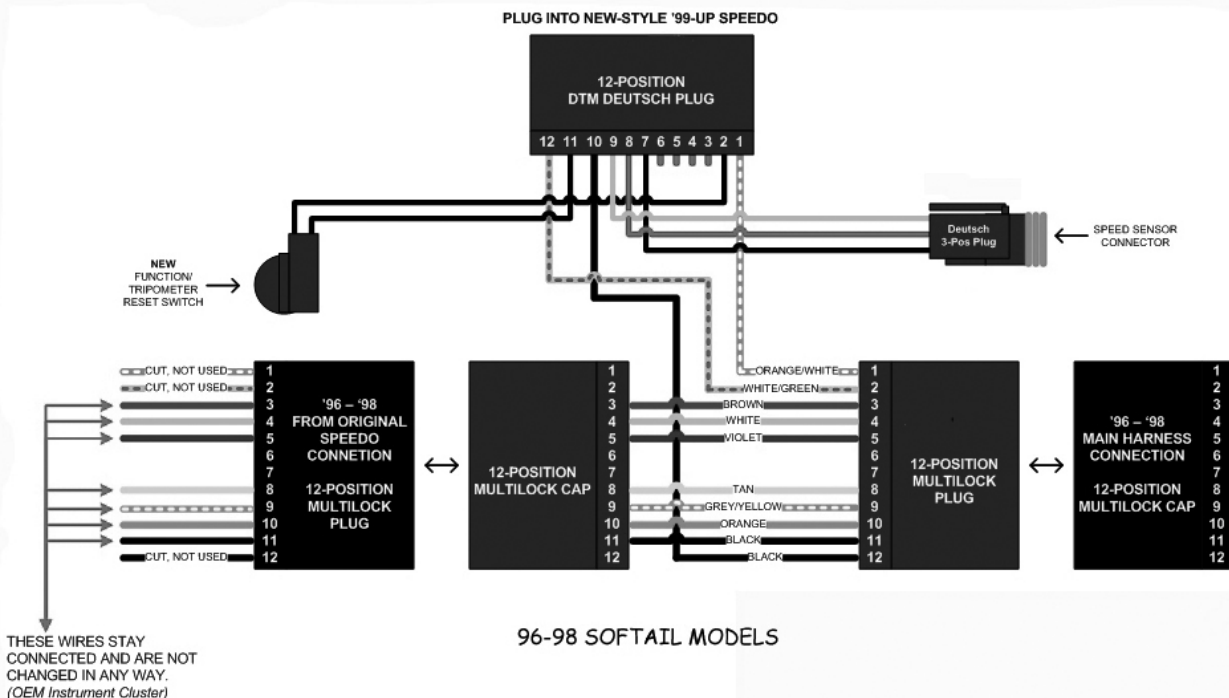

### 99 FXST MODELS:

1. Remove the instrument panel nut and lift panel from tank. Disconnect the 12-pin connector to the speedometer and remove the dash panel from the bike.
2. Remove the speedometer trip reset switch from the dash panel.
3. Remove the speedometer head by releasing the three latches under the speedometer and removing the speedometer head through the top of the dash panel.
4. Install the original rubber gasket from the old speedometer onto the new speedometer and install the new speedometer into the dash panel. Make sure all three latches are secure.
5. Install the new reset switch into the dash housing.
6. Plug the new 12-pin connector into the mating connector on the back of the speedometer head.
7. Reconnect the ignition switch connector under the dash.
8. Connect the three-wire connector to the existing speed sensor.
9. Center the dash panel over the gas tank and install the mounting hardware to secure the dash panel.
10. Reconnect the battery cables, making sure that the negative cable is always reconnected last.
11. Check operation of the speedometer and all indicator lamps.
12. Clear diagnostic codes by doing the following steps:
13. Turn the ignition from Off to On while holding in the reset button on the dash.
14. The code "d0IClr" will be displayed; release the reset button.
15. Press the reset button again and hold button in. Code "d02Set" will be shown. Hold button in until code "d02Clr" is displayed. This indicates that the set code has been cleared. Release the reset button.
16. Exit the diagnostic mode by turning the ignition switch from On to Off to On, without holding in the reset button on the dash panel.

### 00-03 FXST MODELS:

1. Remove the instrument panel nut and lift panel from tank. Disconnect the 12-pin connector to the speedometer and also the connector at the ignition switch and remove the dash panel from the bike.
2. Remove the speedometer trip reset switch from the dash panel.
3. Remove the speedometer head by releasing the three latches under the speedometer and removing the speedometer head through the top of the dash panel.
4. Install the original rubber gasket from the old speedometer onto the new speedometer and install the new speedometer into the dash panel. Make sure all three latches are secure.
5. Install the reset switch into the dash housing.
6. Plug the 12-pin connector into the mating connector on the back of the speedometer head.
7. Reconnect the ignition switch connector under the dash.
8. Center the dash panel over the gas tank and install the mounting hardware to secure the dash panel.
9. Reconnect the battery cables, making sure that the negative cable is always reconnected last.
10. Check operation of the speedometer and all indicator lamps.
11. Clear diagnostic codes by doing the following steps:
12. Turn the ignition from Off to On while holding in the reset button on the dash.
13. The code "d0IClr" will be displayed; release the reset button.
14. Press the reset button again and hold button in. Code "d02Set" will be shown. Hold button in until code "d02Clr" is displayed. This indicates that the set code has been cleared. Release the reset button.
15. Exit the diagnostic mode by turning the ignition switch from On to Off to On, without holding in the reset button on the dash panel.



# INSTALLATION INSTRUCTIONS

## DRAG SPECIALTIES ELECTRONIC SPEEDOMETER P/N 2210-0104

### 96-97 FXDWG MODELS:

**NOTE:** Installation of this later version of speedometer head onto 96-97 Dyna Wide Glide models will require the use of a sub wire harness with 12-pin connectors, Drag Specialties **PART #2120-0294**.

1. Remove the instrument panel nut and lift panel from tank. Disconnect the 12-pin connector to the speedometer and also the connector at the ignition switch and remove the dash panel from the bike.
2. Remove the speedometer trip reset switch from the dash panel.
3. Disconnect the three-wire connection going to the speedometer sensor in the transmission.
4. On the back of the original speedometer, you will find that there are four wires from the speedometer to the 12-pin connector. Either remove these four wires from the connector, or cut them to separate the speedometer from the 12-pin connector.

**NOTE:** These four wires should be color-coded with one being orange/white, one white/green, one black/yellow and one black.

5. If you cut the wires, tape them off so there is no chance of any wire shorting out.
6. Remove the speedometer head by releasing the three latches under the speedometer and removing the speedometer head through the top of the dash panel.
7. Install the original rubber gasket from the old speedometer onto the new speedometer and install the new speedometer into the dash panel. Make sure all three latches are secure.

8. Install the **PART #2120-0294** sub wire harness in between the two original wire harness connectors. Make sure that both connectors are fully seated and locked.
9. Install the new reset switch into the dash housing.
10. Plug the new 12-pin connector into the mating connector on the back of the speedometer head.
11. Reconnect the original wires to the ignition switch.
12. Connect the three-wire connector to the existing speed sensor.
13. Center the dash panel over the gas tank and install the mounting hardware to secure the dash panel.
14. Connect the wires from the sub wire assembly to the existing wires from the speed sensor.
15. Reconnect the battery cables, making sure that the negative cable is always reconnected last.
16. Check operation of the speedometer and all indicator lamps.
17. Clear diagnostic codes by doing the following steps:
18. Turn the ignition from Off to On while holding in the reset button on the dash.
19. The code "d01Clr" will be displayed; release the reset button.
20. Press the reset button again and hold button in. Code "d02Set" will be shown. Hold button in until code "d02Clr" is displayed. This indicates that the set code has been cleared. Release the reset button.
21. Exit the diagnostic mode by turning the ignition switch from On to Off to On, without holding in the reset button on the dash panel.

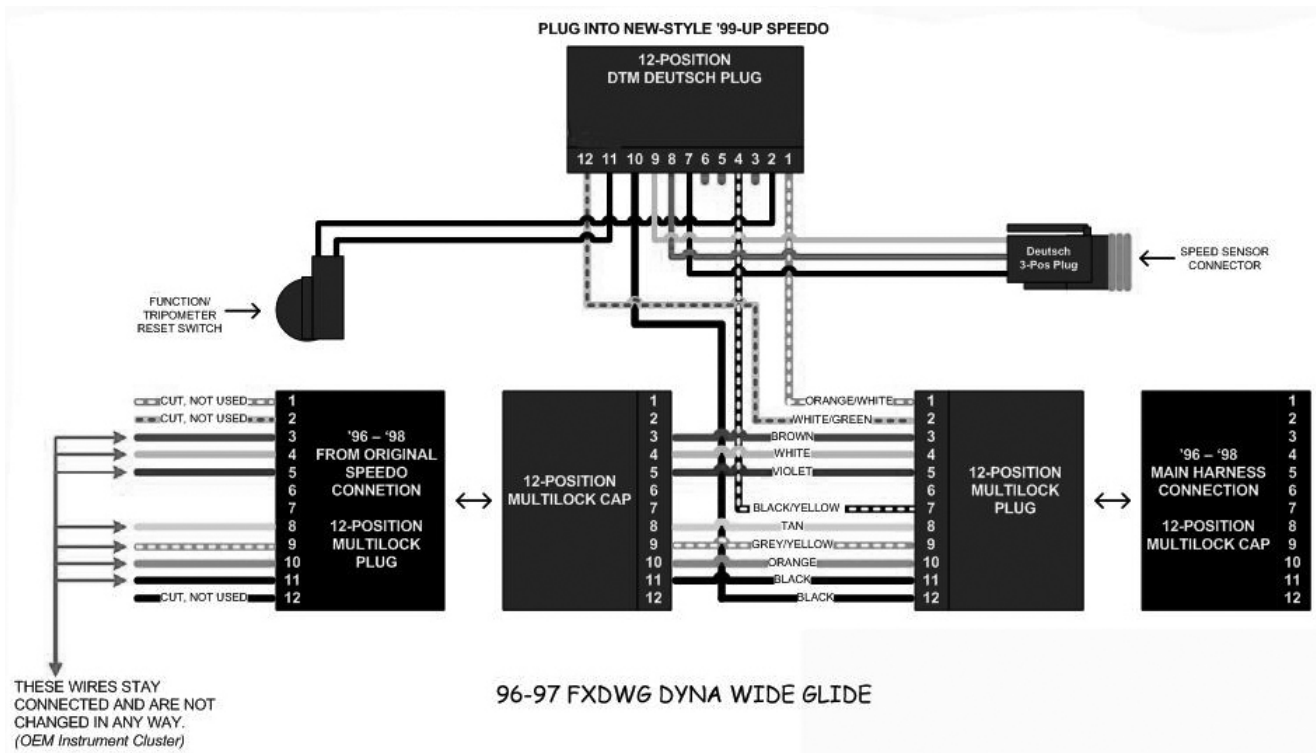

# INSTALLATION INSTRUCTIONS

## DRAG SPECIALTIES ELECTRONIC SPEEDOMETER P/N 2210-0104

### 98 FXDWG MODELS:

**NOTE:** Installation of this later version of speedometer head onto 98 Dyna Wide Glide models will require the use of a sub wire harness with 14-pin connectors, Drag Specialties **PART #2120-0295**.

1. Remove the instrument panel nut and lift panel from tank. Disconnect the 14 pin connector to the speedometer and also the connector at the ignition switch and remove the dash panel from the bike.
2. Remove the speedometer trip reset switch from the dash panel.
3. Disconnect the three-wire connection going to the speedometer sensor in the transmission.
4. On the back of the original speedometer, you will find that there are four wires from the speedometer to the 14-pin connector. Either remove these four wires from the connector, or cut them to separate the speedometer from the 14-pin connector.

**NOTE:** These four wires should be color coded with one being orange/white, one white/green, one black/yellow and one black.

5. If you cut the wires, tape them off so there is no chance of any wire shorting out.
6. Remove the speedometer head by releasing the three latches under the speedometer and removing the speedometer head through the top of the dash panel.
7. Install the original rubber gasket from the old speedometer onto the new speedometer and install the new speedometer into the dash panel. Make sure all three latches are secure.

8. Install the **PART #2120-0295** sub wire harness in between the two original wire harness connectors. Make sure that both connectors are fully seated and locked.
9. Install the new reset switch into the dash housing.
10. Plug the new 12-pin connector into the mating connector on the back of the speedometer head.
11. Reconnect the original wires to the ignition switch.
12. Connect the three-wire connector to the existing speed sensor.
13. Center the dash panel over the gas tank and install the mounting hardware to secure the dash panel.
14. Connect the wires from the sub wire assembly to the existing wires from the speed sensor.
15. Reconnect the battery cables, making sure that the negative cable is always reconnected last.
16. Check operation of the speedometer and all indicator lamps.
17. Clear diagnostic codes by doing the following steps:
18. Turn the ignition from Off to On while holding in the reset button on the dash.
19. The code "d01Clr" will be displayed; release the reset button.
20. Press the reset button again and hold button in. Code "d02Set" will be shown. Hold button in until code "d02Clr" is displayed. This indicates that the set code has been cleared. Release the reset button.
21. Exit the diagnostic mode by turning the ignition switch from On to Off to On, without holding in the reset button on the dash panel.

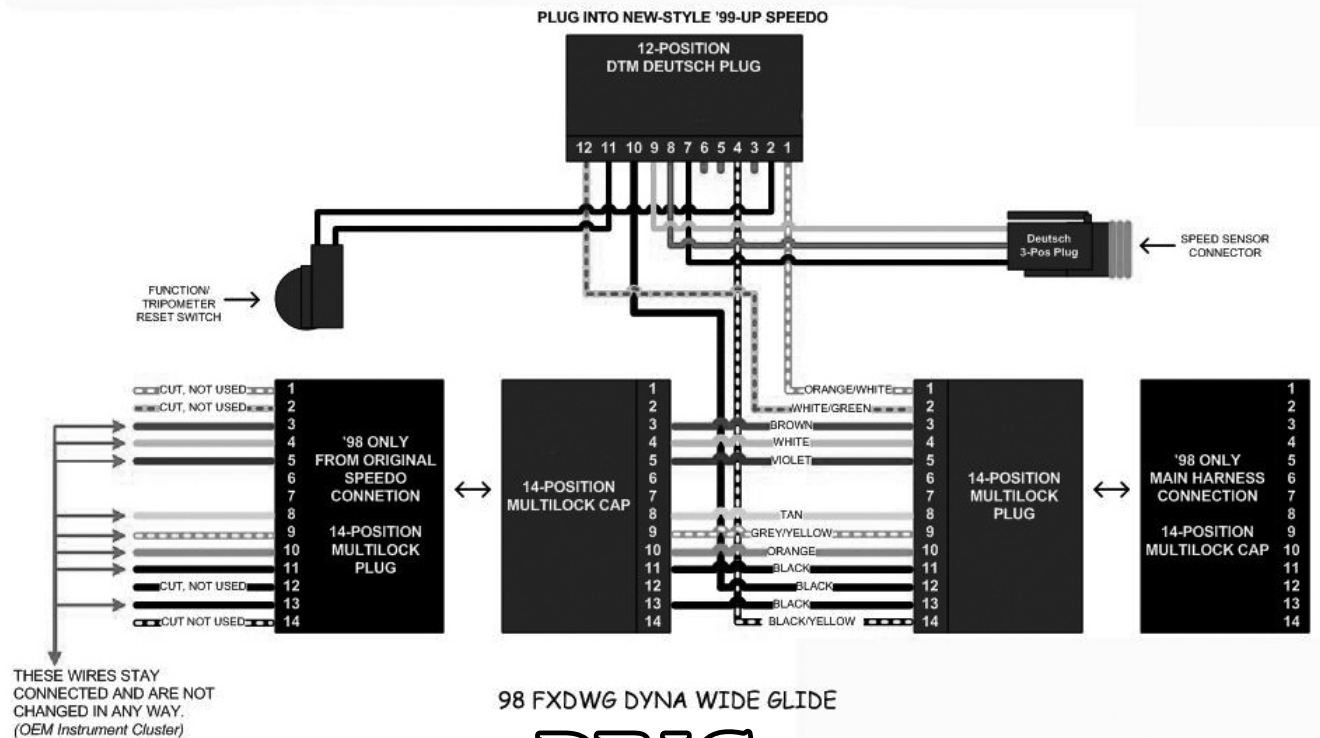



# INSTALLATION INSTRUCTIONS

## DRAG SPECIALTIES ELECTRONIC SPEEDOMETER P/N 2210-0104

### 99-03 DYNA WIDE GLIDE MODELS:

1. Remove the instrument panel nut and lift panel from tank. Disconnect the 12-pin connector to the speedometer and also the connector at the ignition switch and remove the dash panel from the bike.
2. Remove the speedometer trip reset switch from the dash panel.
3. Remove the speedometer head by releasing the three latches under the speedometer and removing the speedometer head through the top of the dash panel.
4. Install the Original rubber gasket from the old speedometer onto the new speedometer and install the new speedometer into the dash panel. Make sure all three latches are secure.
5. Install the reset switch into the dash housing.
6. Plug the 12-pin connector into the mating connector on the back of the speedometer head.
7. Reconnect the ignition switch connector under the dash.
8. Center the dash panel over the gas tank and install the mounting hardware to secure the dash panel.
9. Reconnect the battery cables, making sure that the negative cable is always reconnected last.
10. Check operation of the speedometer and all indicator lamps.
11. Clear diagnostic codes by doing the following steps:
12. Turn the ignition from Off to on while holding in the reset button on the dash.
13. The code "d01Clr" will be displayed; release the reset button.
14. Press the reset button again and hold button in. Code "d02Set" will be shown. Hold button in until code "d02Clr" is displayed. This indicates that the set code has been cleared. Release the reset button.
15. Exit the diagnostic mode by turning the ignition switch from On to off to on, without holding in the reset button on the dash panel.

### 96-97 FLHR ROAD KING MODELS:

**NOTE:** Installation of this later version of speedometer head onto 96-97 Road King models will require the use of a sub wire harness with 12-pin connectors, Drag Specialties **PART #2120-0302**.

1. Remove the instrument panel nut and lift panel from tank. Disconnect the 12-pin connector to the speedometer and also the connector at the ignition switch and remove the dash panel from the bike.
  2. Remove the speedometer trip reset switch from the dash panel.
  3. Disconnect the three-wire connection going to the speedometer sensor in the transmission.
  4. On the back of the original speedometer, you will find that there are four wires from the speedometer to the 12-pin connector. Either remove these four wires from the connector, or cut them to separate the speedometer from the 12-pin connector.
- NOTE:** These four wires should be color-coded with one being orange/white, one white/green, one black/yellow and one black. The 12-pin connector should be located under the left side cover.
5. If you cut the wires, tape them off so there is no chance of any wire shorting out.
  6. Remove the speedometer head by releasing the three latches under the speedometer and removing the speedometer head through the top of the dash panel.
  7. Install the original rubber gasket from the old speedometer onto the new speedometer and install the new speedometer into the dash panel. Make sure all three latches are secure.
  8. Install the **PART #2120-0302** sub wire harness in between the two original wire harness connectors. Make sure that both connectors are fully seated and locked.
  9. Install the new reset switch into the dash housing.
  10. Plug the new 12-pin connector into the mating connector on the back of the speedometer head.
  11. Reconnect the original wires to the ignition switch.
  12. Connect the three-wire connector to the existing speed sensor.
  13. Center the dash panel over the gas tank and install the mounting hardware to secure the dash panel.
  14. Connect the three wires from the sub wire assembly to the existing wires from the speed sensor.
  15. Reconnect the battery cables, making sure that the negative cable is always reconnected last.
  16. Check operation of the speedometer and all indicator lamps.
  17. Clear diagnostic codes by doing the following steps:
  18. Turn the ignition from Off to On while holding in the reset button on the dash.
  19. The code "d01Clr" will be displayed; release the reset button.
  20. Press the reset button again and hold button in. Code "d02Set" will be shown. Hold button in until code "d02Clr" is displayed. This indicates that the set code has been cleared. Release the reset button.
  21. Exit the diagnostic mode by turning the ignition switch from On to Off to On, without holding in the reset button on the dash panel.





# INSTALLATION INSTRUCTIONS

## DRAG SPECIALTIES ELECTRONIC SPEEDOMETER P/N 2210-0104

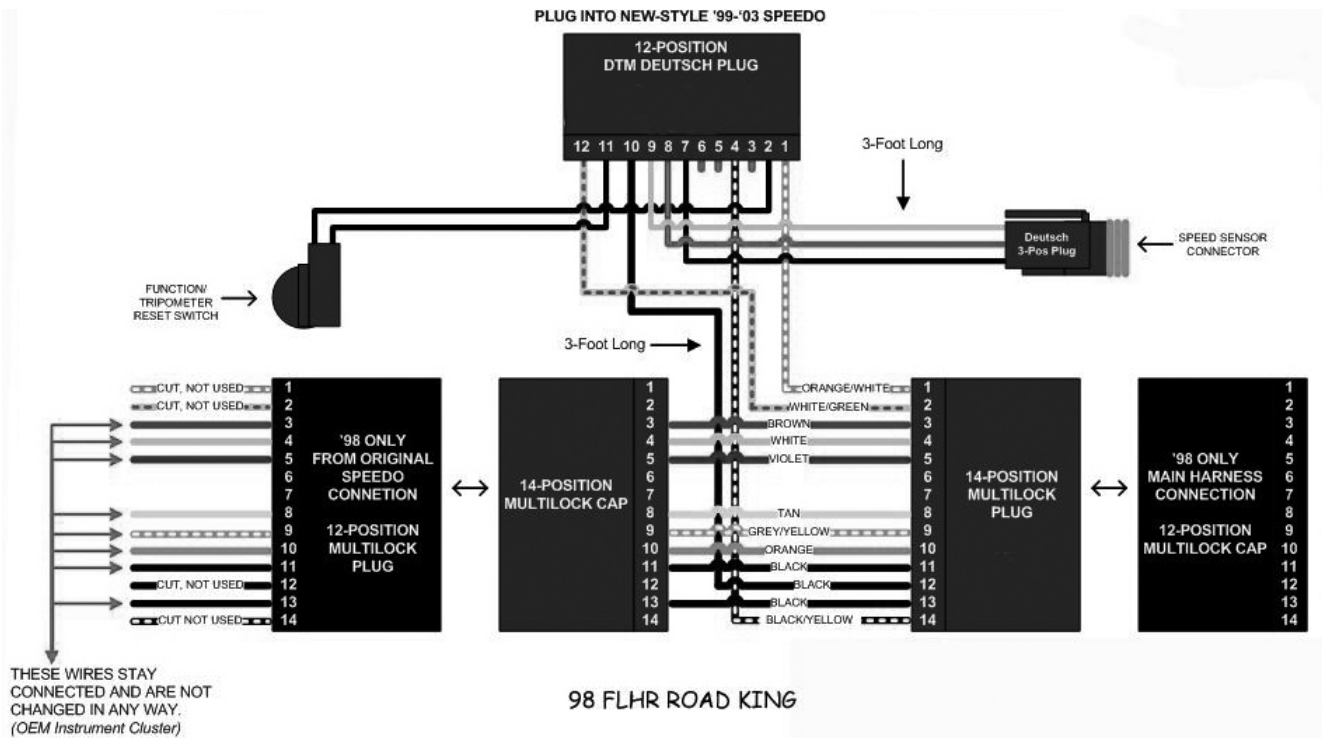

### 99-03 FLHR ROAD KING MODELS:

1. Remove the instrument panel nut and lift panel from tank. Disconnect the 12-pin connector to the speedometer and also the connector at the ignition switch and remove the dash panel from the bike.
2. Remove the speedometer trip reset switch from the dash panel.
3. Remove the speedometer head by releasing the three latches under the speedometer and removing the speedometer head through the top of the dash panel.
4. Install the original rubber gasket from the old speedometer and install the new speedometer into the dash panel. Make sure all three latches are secure.
5. Install the reset switch into the dash housing.
6. Plug the 12-pin connector into the mating connector on the back of the speedometer head.
7. Reconnect the ignition switch connector under the dash.
8. Center the dash panel over the gas tank and install the mounting hardware to secure the dash panel.
9. Reconnect the battery cables, making sure that the negative cable is always reconnected last.
10. Check operation of the speedometer and all indicator lamps.
11. Clear diagnostic codes by doing the following steps:
12. Turn the ignition from Off to On while holding in the reset button on the dash.
13. The code "d01Clr" will be displayed; release the reset button.
14. Press the reset button again and hold button in. Code "d02Set" will be shown. Hold button in until code "d02Clr" is displayed. This indicates that the set code has been cleared. Release the reset button.
15. Exit the diagnostic mode by turning the ignition switch from On to Off to On, without holding in the reset button on the dash panel.

**WARNING!:** Before operating motorcycle, be sure all hardware is tight.

