

# INSTALLATION INSTRUCTIONS

## DRAG SPECIALTIES REPLACEMENT LENS KIT FOR FLHTCU TOURPAKS P/N 2010-0569/0570/0571

### ATTENTION INSTALLER (if other than owner):

Please forward this Instruction Sheet to the purchaser of this product. These instructions contain valuable information necessary to the end user.

**INTRODUCTION:** These instructions describe the procedure for properly installing the replacement taillight lens on the 1989-2012 FLHTCU TourPak.

Review instructions carefully before beginning, as they contain important information. Please retain for future reference.

Particularly important information is distinguished in these instructions by the following notations:

**NOTE: A NOTE** provides key information to make procedures easier or clearer.

**CAUTION: A CAUTION** indicates special procedures that must be followed to avoid damage to the motorcycle and/or accessories.

### **WARNING!:** A WARNING

indicates special procedures that must be followed to avoid injury to a motorcycle operator or person inspecting or repairing the motorcycle.



### TOOLS REQUIRED:

Wooden dowel or plastic tube push stick  
(1" maximum diameter)

Flat screwdriver with a wide, thin blade, or similar  
Appropriate light bulbs for use with the smoked or  
clear lenses (red 1157 style)

Automotive Window/body sealer (if required)

### PROCEDURE

#### LENS REMOVAL:

1. Open TourPak and remove all items, including any cushions, mats or pockets fastened to the rear of the TourPak.
2. Remove the light bulbs and sockets from the taillight housing by depressing the tab on the socket assembly and turning counter clockwise. Remove the bulb from the socket.
3. Removing the lenses from the wrap-around light housing:

**NOTE:** Warming the lenses and housing slightly makes it much easier to remove and install the lenses. Warm these with a heat gun or hair dryer, being careful not to damage the housing, lenses or paint with excessive heat. These lenses are held in place by a soft, black sealant. There are also three alignment tabs on the lens that clip into the lens frame. To remove the lens, insert the dowel or plastic tube through the hole in the back of the light housing and firmly push the lens outward toward the rear of the bike. This action places a stress on the alignment tabs.

4. Using a wide, thin, flat blade screwdriver, pry the lens away from the frame at the rear top, side and bottom to release the three lens alignment tabs. Again use the dowel or plastic tube to push the lens out rearward. It may be necessary to repeat the prying process and pushing process several times to remove the lens.

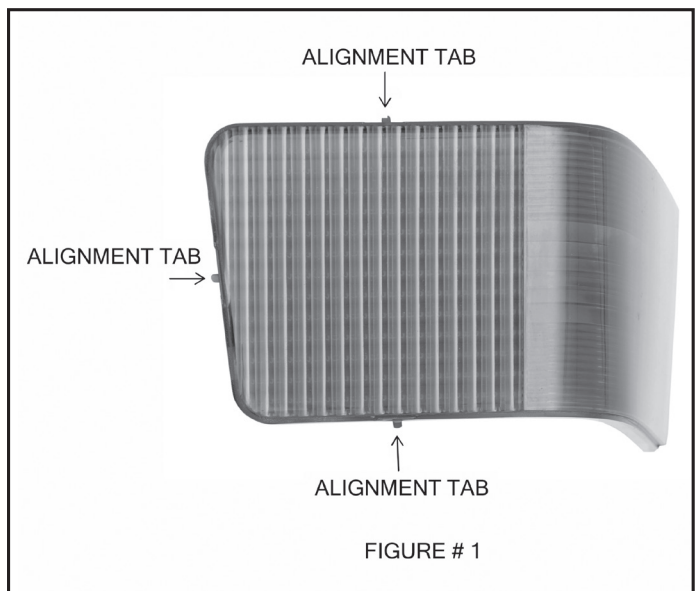

3501 Kennedy Rd, PO Box 5222, Janesville, WI 53547-5222

# INSTALLATION INSTRUCTIONS

## DRAG SPECIALTIES REPLACEMENT LENS KIT FOR FLHTCU TOURPAKS P/N 2010-0569/0570/0571

SIDEVIEW OF TOURPAK LENS

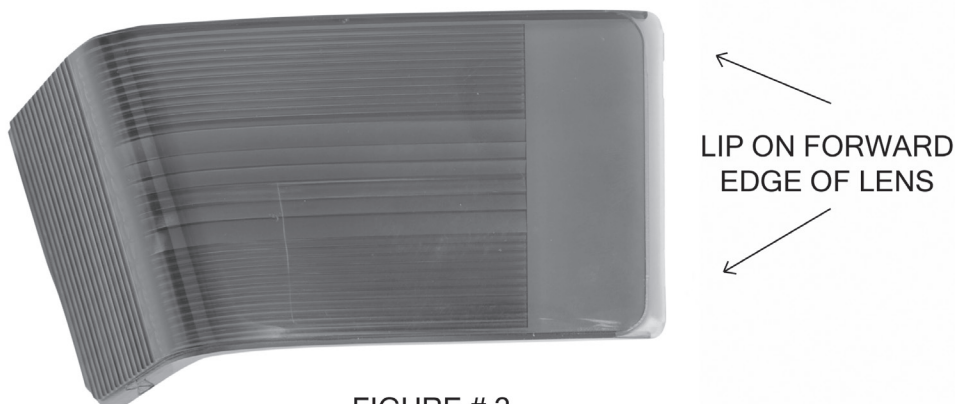

FIGURE # 2

5. When the lens begins to emerge from the frame, grasp it at the top and bottom and pull the lens from the housing toward the rear, using an up-and-down motion.

**CAUTION:** Never allow the light housing or painted parts to come in contact with the sealant on the lenses.

6. If there is sufficient sealant remaining in the housing, installation of the new lenses may proceed without adding additional sealant. Insufficient sealant may allow the lenses to work out over a period of time.

### LENS INSTALLATION:

**NOTE:** Do not use RTV or silicone sealer to reset the lens. If sealant is needed, obtain a non-hardening automotive body/windshield sealant from your local glass installer.

7. Note the lip on the front edge of the new lenses. Place the lens into the body of the taillight housing, and push it forward so this lip engages the slot in the housing.

8. Work the lens up and down to settle it all the way into the slot.

9. At the rear of the housing, push in the lens to engage the three alignment tabs, one each on the side, top and bottom of the lens.

**NOTE:** If the lens is not seated far enough forward, the alignment tabs will be hard to seat properly and may want to push it back out.

10. Clean any sealant off the exterior of the TourPak using a solvent recommended by the sealant manufacturer.

11. Allow sealant to cure overnight before operation of the motorcycle.

12. Install the correct taillight bulbs. The smoked or clear style of lenses must use a red colored bulb. The red lenses can use a clear bulb.

13. Test light operation.

**WARNING!:** Before operating the motorcycle, be sure all hardware is tight.

