



WINCH MOUNT

2014 POLARIS RZR 1000 & RZR-4 1000

P/N: 4505-0542

Item	Qty.	Part #	Description
1	1	1608-100	Main Mount Plate
2	1	1608-2	RH Roller Fairlead Adapter
3	1	1608-3	LH Roller Fairlead Adapter
4	4	HDW2122	3/8" x 1" Carriage Bolts
5	4	HDW7061	3/8" Nylock Nuts

NOTE: Roller fairlead not included with this kit!

INSTALLATION:

1. Remove the front plastic panel over the roller fairlead opening.
2. Slide the mount in place directly over the front differential per the illustrations on the back page. The front and back of the mount will bolt through existing holes in the chassis.
3. Line up the holes in the front of the mount with the square holes in the front frame tubes. Bolt in place from the front through the frame and then the mount using two 3/8" x 1" carriage bolts (#4). Loosely secure with two 3/8" nylock nuts (#5).
4. Align the rear holes in the plate with the existing square holes in the rear frame tubes. Loosely bolt in place from the back in the same fashion as the front. After all bolts have been started, tighten all the hardware.
5. Slide the winch in place from the side of the machine. Bolt the winch to the mount using the hardware provided with the winch.
6. This mount accepts both standard and wide roller fairleads using the adapter brackets (#2/3). Remove the four factory bolts around the roller fairlead opening in the chassis. Align the adapter brackets so they face inward and the fairlead holes will be towards the top. Now install the fairlead brackets to the machine using the same four factory bolts. Install the roller fairlead or hawse to the fairlead brackets using the hardware that came with your winch. Pull the cable through the fairlead and install the hook.
7. Wire your winch according to the winch manufacturers instructions.

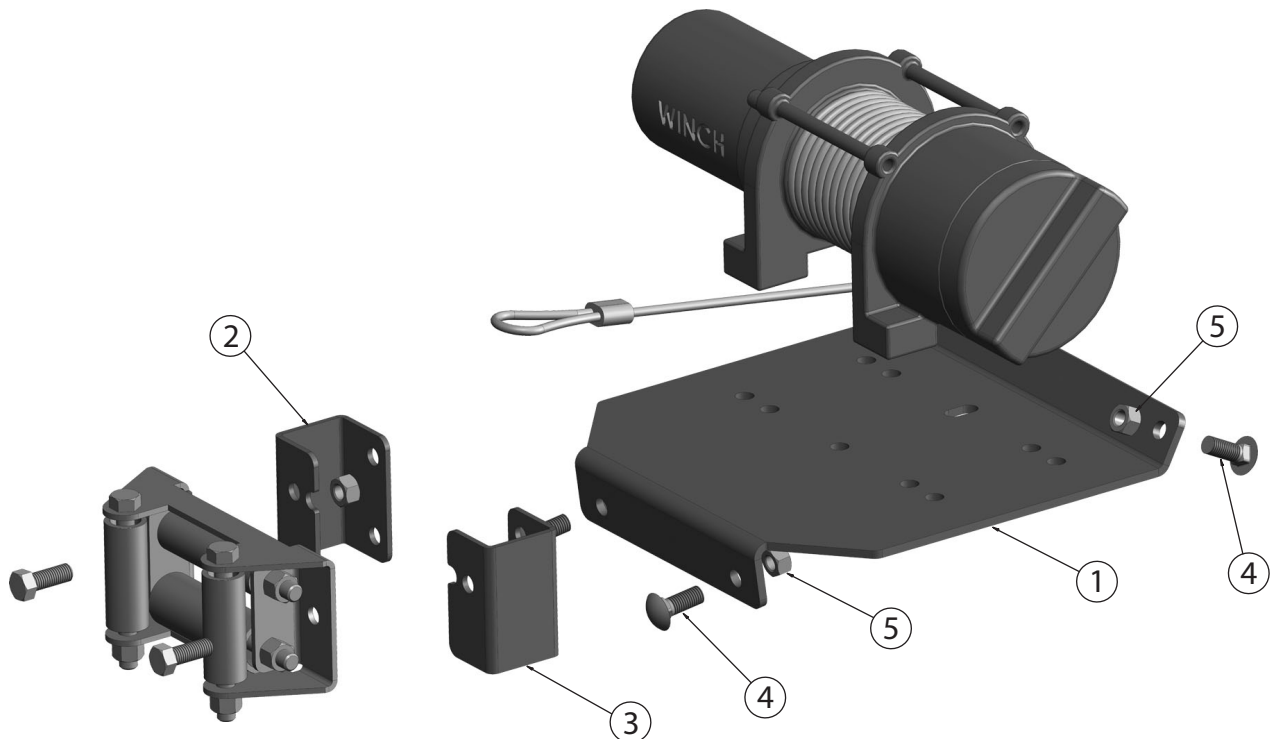

FOR QUESTIONS REGARDING YOUR ORDER OR RETURNS CONTACT THE COMPANY YOU PURCHASED FROM.
FOR TECHNICAL OR INSTALLATION QUESTIONS PLEASE CALL THE MANUFACTURER: **763-689-4800**

Winch Mount Installation Instructions

Polaris RZR 1000

PAGE 2

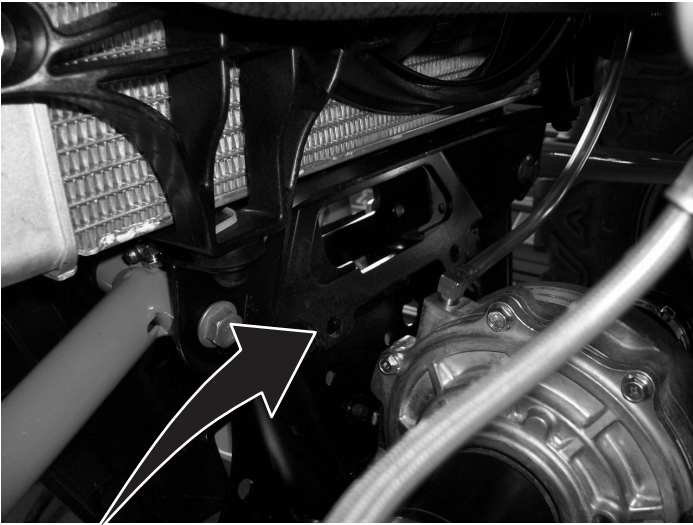

Bolt the front of the mount to these existing holes.

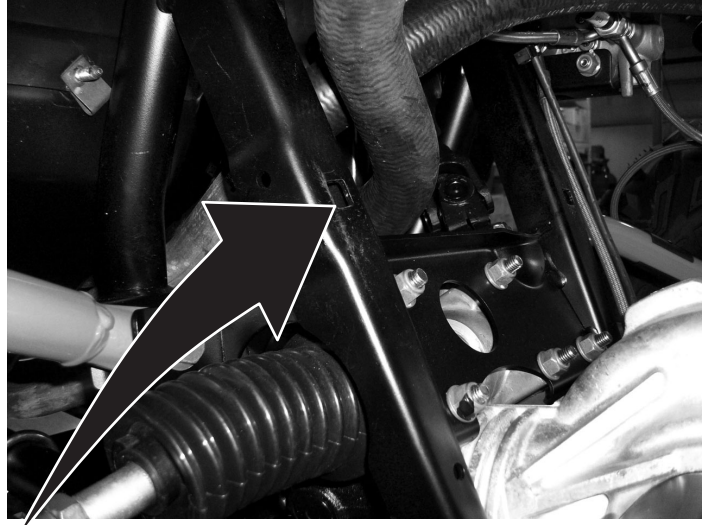

The rear of the mount will bolt through the square holes.

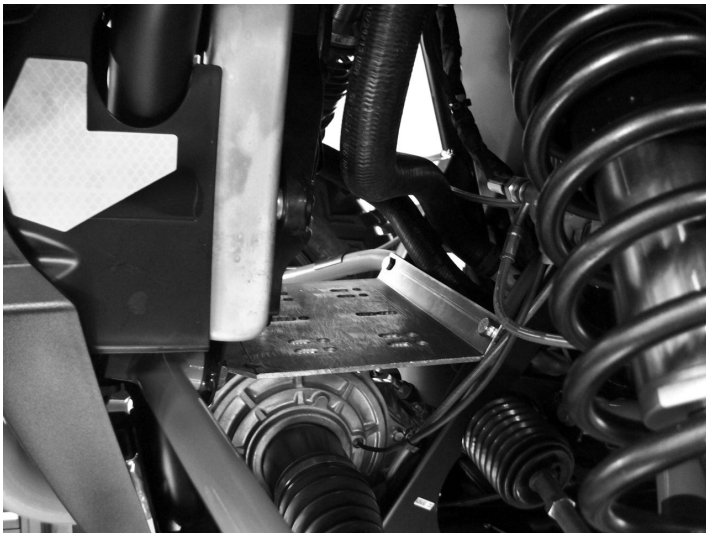

Winch mount bolted in place.

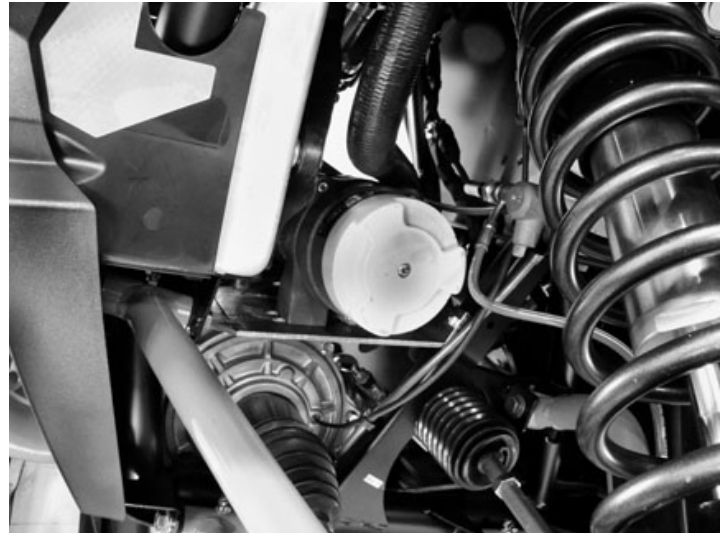

Winch properly installed on the machine.

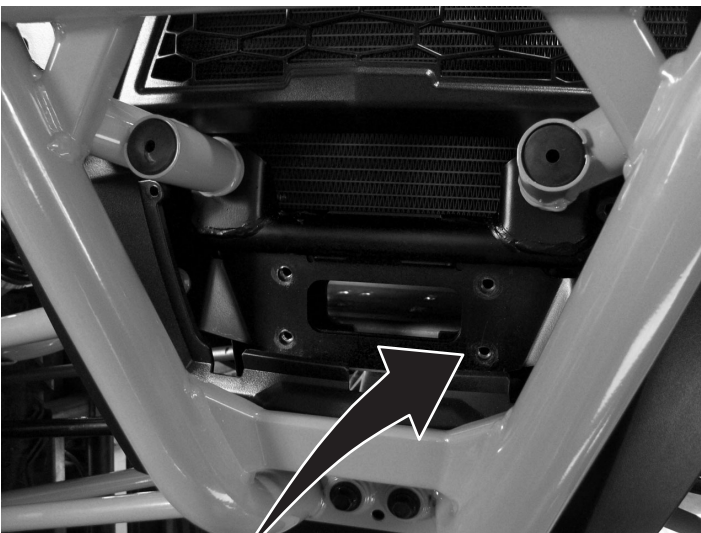

Remove these four factory bolts.

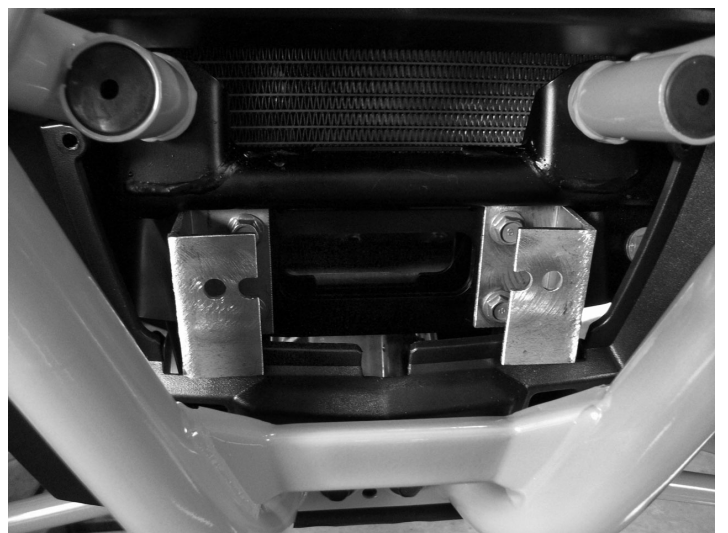

Fairlead brackets properly installed.

FOR QUESTIONS REGARDING YOUR ORDER OR RETURNS CONTACT THE COMPANY YOU PURCHASED FROM.
FOR TECHNICAL OR INSTALLATION QUESTIONS PLEASE CALL THE MANUFACTURER: **763-689-4800**