



Ref#.	Qty.	Part #	Description
1	1	1620-1	Winch Mount Plate
2	6	HDW7058	5/16" Nylock Nuts
3	4	HDW2050	5/16" X 3/4" Hex Bolts
4	4	HDW9002	5/16" Flat Washers
5	2	HDW2061	5/16 x 1-1/4" Hex Bolts

**NOTE: Roller fairlead not included with this kit!**

## Winch Mount Installation Instructions

### 2011 Can-Am Commander

Part Number: 1620M (4505-0437)

1. Remove the front plastic bumper cover and smaller plastic shroud behind the towhook loop. You will not re-use the towhook shroud.
2. Position the winch mount in place on the machine as illustrated below. The front mounting holes in the winch mount align with the holes in the horizontal front bumper tube. The rear mounting holes align with the holes in the vertical radiator support tubes. Bolt in place using four 5/16" x 3/4" hex bolts (#3), four 5/16" flat washers (#4), and four 5/16" nylock nuts (#2).
3. Install your winch to the plate using the hardware supplied with your winch. Make sure to orientate your winch so the cable pulls off the bottom of the drum. Pull a small amount of cable out through the fairlead hole in the mount plate.
4. Reinstall the plastic bumper cover. Do not reinstall the towhook shroud. This mount accept both sizes of roller fairleads, you will only use the one set of holes that match up with your roller fairlead. Install your roller fairlead over the plastic bumper cover and bolt in place using two 5/16" x 1-1/4" (#5) hex bolts and 5/16" nylock nuts (#2). If using the narrower roller fairlead you will need to drill or ream out the plastic bumper cover for the bolts to clear. Use a 5/16" drill bit or round file to notch out the plastic. Pull the cable through the fairlead and install the hook.

**NOTE:** If using a synthetic rope with aluminum hawse you will need to use the hardware provided with your winch to mount the hawse.

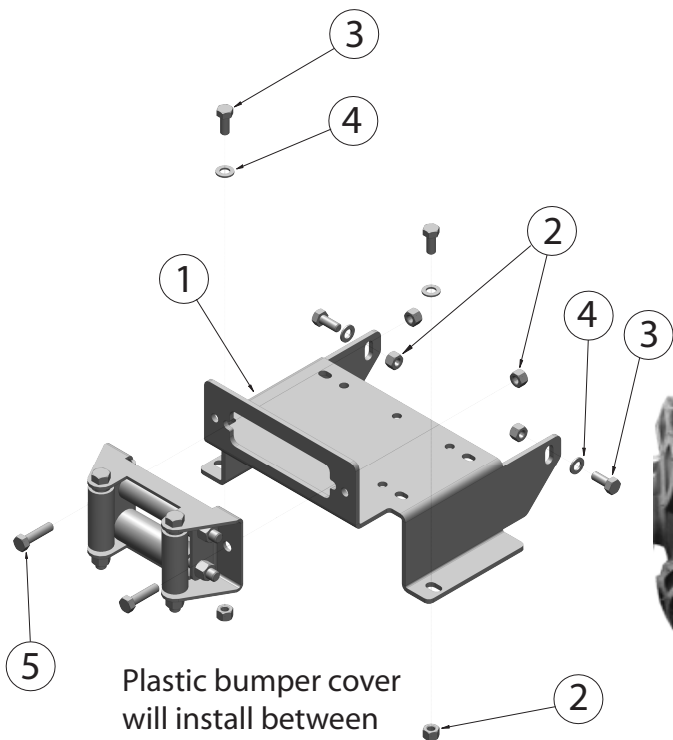

Plastic bumper cover will install between the mount plate and roller fairlead.

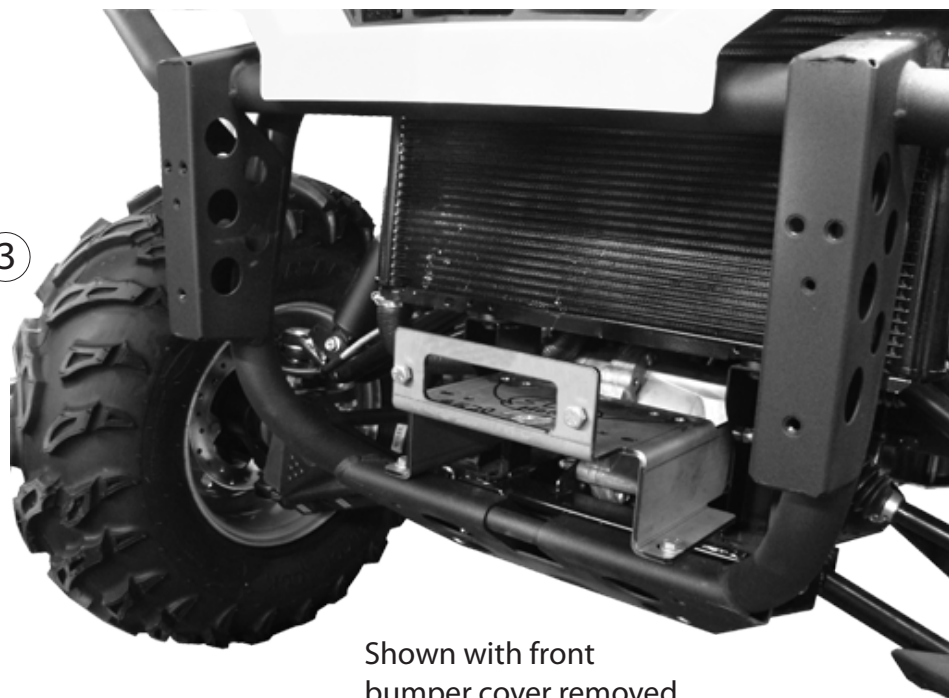

Shown with front bumper cover removed.

FOR QUESTIONS OR COMMENTS PLEASE CALL THE MANUFACTURER: **763-689-4800**

All images used are copyrighted property of CMP and may not be used without permission. Inst1620M 01/03/2011