



Ref#.	Qty.	Part #	Description
1	1	1615-1	Winch Mount Plate
2	6	HDW7058	5/16 Nylock Nuts
3	6	HDW2050	5/16" X 3/4" Hex Bolts
4	2	HDW9002	5/16" Flat Washers

Winch Mount Installation Instructions

2009 Ranger 500, 700 XP, 2010 Ranger 800

Part Number: 1615M (4505-0407)

1. Remove the front metal screen from underneath the hood latch area and retain the hardware. Remove the one-piece front bumper assembly and retain the hardware.
2. Loosely install the back tabs of the main winch mount plate on the frame rail just beneath the radiator per the illustration. Hand tighten only with two 5/16" x 3/4" hex bolts (#3), flat washers (#4), and 5/16" nylock nuts (#2).
3. Set your winch in place on top of the mount plate but do not bolt in yet. Make sure to orientate your winch so the cable pulls off the bottom of the drum. Pull a small amount of cable out through the fairlead hole in the mount plate.
4. Put the front bumper back in place on the machine but do not tighten the bolts yet. Using two 5/16" x 3/4" hex bolts (#3) and 5/16" nylock nuts (#2), bolt the front bumper to the two upper corners of the winch plate on each side of the fairlead. Hand tighten only. See Illustration.
5. Install your roller fairlead (#5) on the outside of the mount plate with two 5/16" x 3/4" hex bolts (#3) and 5/16" nylock nuts (#2) (rollers should turn freely). The larger roller goes on the bottom. **Note:** Bottom roller may need to be removed to run the wire rope through. If using an aluminum hawse instead of a roller fairlead you may need different hardware, check the hardware that was supplied with your winch.
6. You can now tighten all the bolts starting with the front bumper, front winch plate mount bolts, rear winch plate mount bolts, and roller fairlead bolts.
7. Using the hardware that came with your winch, bolt the winch to the plate. Using the instructions provided with the winch, wire accordingly.
8. Reinstall front metal screen using original hardware. Reinstall stock large black Torx bolts into the two remaining holes in the front of the winch mount

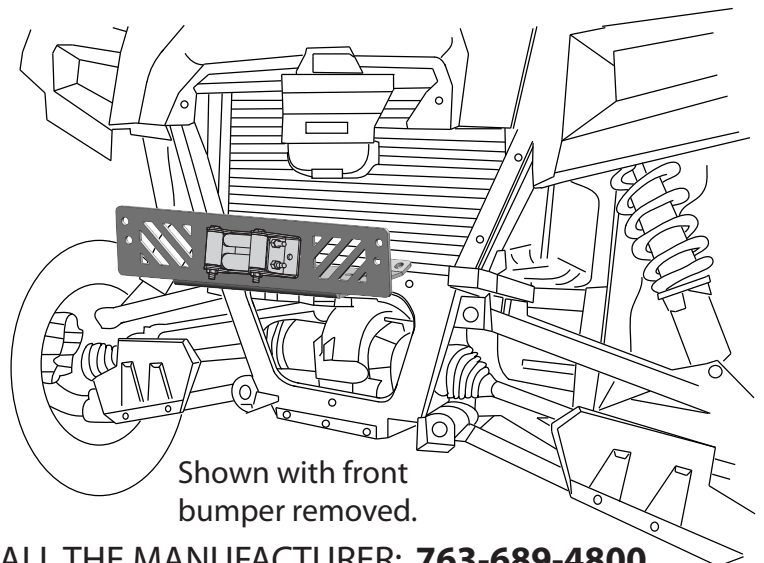
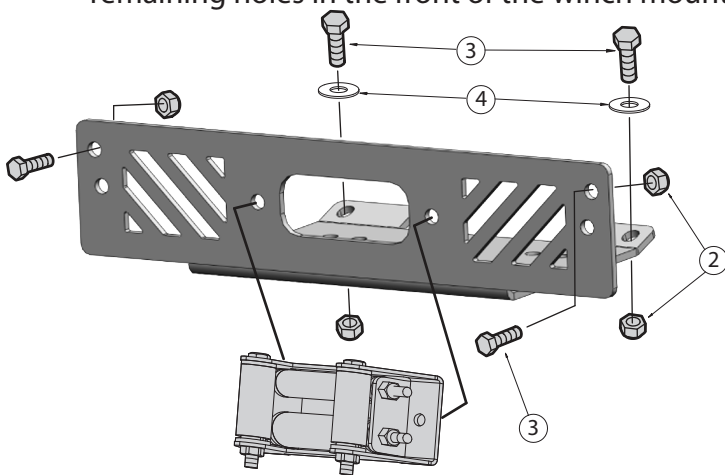

FOR QUESTIONS OR COMMENTS PLEASE CALL THE MANUFACTURER: **763-689-4800**