



# Winch Mount Kawasaki 2008-10 Teryx 750

Item	Qty.	Part#	Description
2	1	1549-1	Main Winch Mount Plate
3	1	1549-2	Roller Fairlead Mount Plate
4	2	1549-3	Angled Support Brackets
5	2	HDW1061	8mm - 1.25 x 30mm Bolts
6	2	HDW2050	5/16" x 3/4" Hex Head Bolts
7	6	HDW2051	5/16" x 1" Hex Head Bolts
8	8	HDW7058	5/16" Nylock Nuts
9	14	HDW9002	5/16" Flat Washers

**NOTE: Roller fairlead not included with this kit!**

**PN: 1549M (4505-0401)**

1. Remove the bumper cover, set aside and retain all hardware.
2. Slide your winch into place behind the front bumper from the front. When standing in front of the machine, the winch motor (on most winch models) should be on the right side. The winch will not be bolted to anything at this point. You can now slide the main winch mount plate (2) into place under the winch from behind the left side of the bumper. The side of the plate with the large cutout will be facing up.
3. Align the holes in the winch mount plate with the four outermost holes in the frame plate and bolt into place using four 5/16" x 1" (#7) hex head bolts, eight 5/16" flat washers (#9), and four 5/16" nylock nuts (#8). You will need to move the winch from side to side in order to access all the holes and bolts.
4. The winch can now be aligned with the 4 bolt holes in the front of the winch mount plate. Using two of the bolts supplied with your winch (Not included in this hardware kit), bolt the winch to the plate using only the two bottom holes making sure the two upper holes still line up with the winch.
5. The two angled support brackets (#4) are designed to go between the front of the main winch mount plate and the back of the roller fairlead mount directly behind the bumper bracket. See Illustration for orientation. There are two holes in the top of each bracket, you will use only the holes that line up with your size of winch. There are also two holes in the bottom of each bracket but you will only use the inner most holes to mount to the frame/bumper crossbrace.
6. Loosely bolt the top of each bracket through the winch mount plate and into the upper winch holes that line up with your winch using two 8mm x 30mm (#5) hex head bolts and 5/16" washers (#9). The roller fairlead mount (#3) can now be slid into place between the frame/bumper crossbrace and the bottom of the angled support brackets. Install two 5/16" x 1" hex head bolts (#7) from the front through the frame/bumper crossbrace, fairlead mount bracket, and angled support brackets. Bolt together using four 5/16" washers (#9) and two nylock nuts (#8). You can now tighten the top bolts as well.
7. Mount the fairlead to the fairlead mount plate using two 5/16" x 3/4" hex head bolts (#6) and 5/16" nylock nuts (#8).
8. Reattach the bumper cover using the stock mounting hardware.

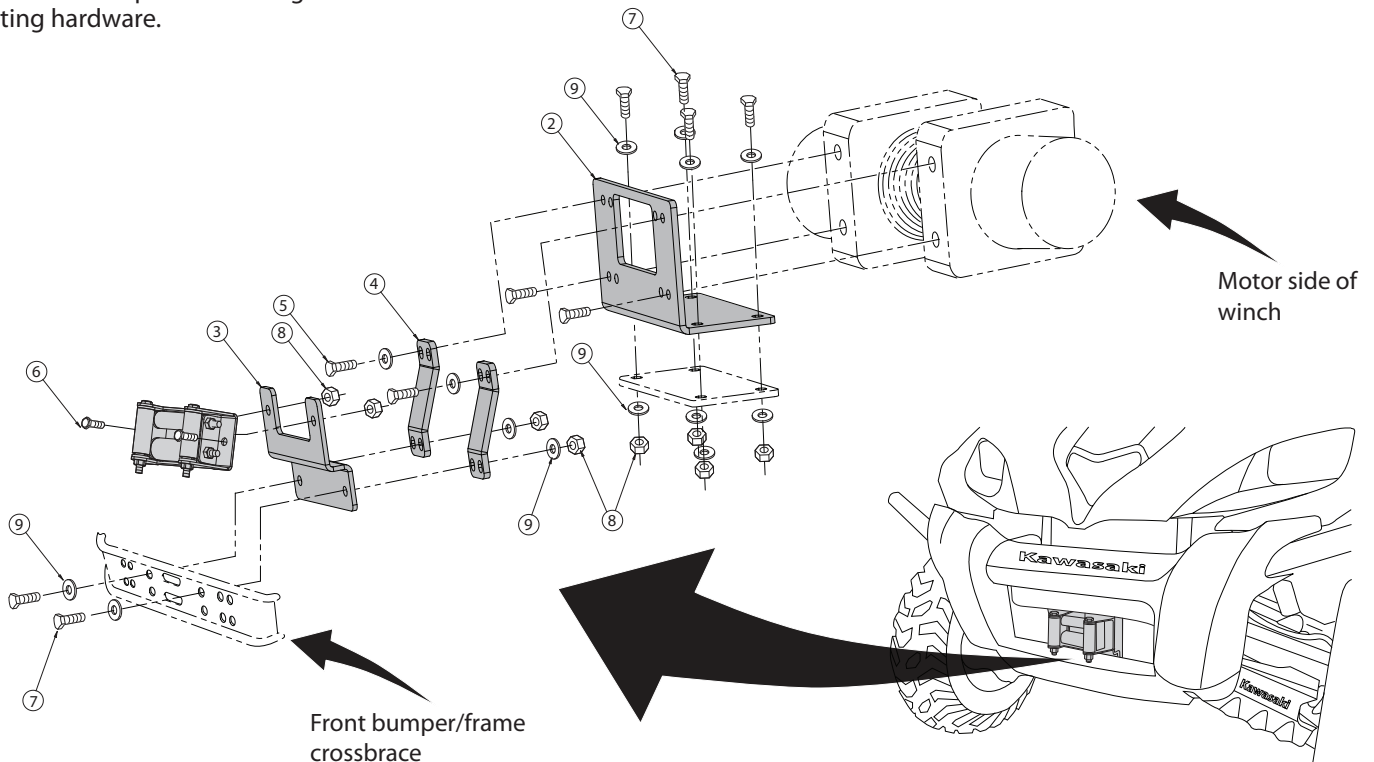

**FOR QUESTIONS OR COMMENTS PLEASE CALL THE MANUFACTURER: 763-689-4800**

All images used are copyrighted property of CMP and may not be used without permission. Inst1549M 04/15/08