



MOOSE RACING

EXPEDITION LUGGAGE

ADVENTURE TOP CASE MOUNT



INCLUDES HARDWARE TO ATTACH MOUNTING PLATE TO YOUR TOP CASE

1510-0219 Kawasaki KLR650 Top Case Mount Kit [2008 - 2014]

FEATURES OF THE EXPEDITION LUGGAGE - ADVENTURE TOP CASE UNIVERSAL MOUNT SET:

- Stylish, laser-cut aluminum mounting plate is powder-coated for excellent durability
- Designed to work perfectly with MOOSE Expedition Top Cases or similar aluminum luggage
- Functions as a sturdy cargo rack when your top case is removed; has various cargo strap attachment slots
- Includes a plastic protector that shields the top case from wear and doubles as a simple and precise drill template
- High-quality, plated hardware includes flange-style bolts, rubber sealing washers & flange-style lock nuts
- Model-specific hardware for simple installation - Designed and built in the U.S.A.

⚠ WARNING

READ THESE INSTRUCTIONS THOROUGHLY BEFORE INSTALLATION!

Because of the variety of motorcycle configurations, other accessories, and the features and intended use of this MOOSE accessory, there are many different mounting options. You are responsible for the proper installation of this accessory on your motorcycle. Download the required instructions for your accessory mount set and motorcycle from www.MOOSERACING.com. Your attention to the installation instructions and recommendations will permit safe and proper use of this accessory. You must mount this accessory properly and securely before riding your motorcycle. If you lack the ability to safely and properly install this accessory, seek out a qualified motorcycle technician for assistance. During installation, support the motorcycle with a suitable stand or lift so it will not tip over and injure you, or damage the vehicle. Using or mounting this accessory improperly could result in a loss of control of the motorcycle which could result in damage to your motorcycle or other personal property, the property of third parties, and/or personal injury to yourself or others, up to and including death.

BE SURE TO THOROUGHLY READ AND CLOSELY FOLLOW THE MOUNTING INSTRUCTIONS THAT ARE INCLUDED WITH THIS ACCESSORY:

- The top case mount must be installed and securely fastened to the motorcycle's rear rack or a similar structure on its frame.
- Install the mount securely so it will not shift or move while riding. Make sure the top case, the mounting plate plus all related brackets and hardware will not contact the wheels, suspension or any other moving parts of the motorcycle.
- If you do not understand these instructions DO NOT install the mount or top case. Remove any components you may have already installed on your motorcycle.
- Thoroughly inspect your motorcycle's luggage mounts, panniers or top case before every ride.
- Do not use the top case if the mount has been modified, or if it has deteriorated, loosened, cracked, or is beginning to fail in any way. Do not use the top case or its mount if your motorcycle's frame is damaged, or if the sub-frame is damaged or is loose on the main chassis.
- Check the security of the top case and the mount at each stop as you ride. Mounting hardware can loosen during operation, so be sure to check it frequently.
- Do not use this accessory mount if you have any doubts as to whether it is properly mounted to your motorcycle.
- Do not exceed 15 pounds (6.8 kg) of cargo in your MOOSE top case.
- When using this accessory, do not exceed your vehicle's Maximum Gross Vehicle Weight as listed on your motorcycle or in its Owner's Manual.
- Be aware that accessory luggage and cargo will affect your vehicle's performance and handling characteristics. Use caution when riding your motorcycle.
- Arrange your cargo placement so it does not shift during riding.
- When riding with luggage mounted to your motorcycle, be aware the width and height of your luggage may exceed the width of your handlebars and the height of the seat. Use extra care when maneuvering in traffic or around other obstacles so you do not impact other objects with your luggage.
- If you strike another object, or tip over your motorcycle, immediately inspect the luggage, the luggage mounts and your vehicle for damage.
- If your luggage or mounts are ever damaged, do not use them until they have been inspected by your local professional motorcycle dealer. Replace these parts immediately if they have damage that will prevent them from being properly secured to your motorcycle or able to securely hold cargo.

DO NOT ATTEMPT TO USE THIS ACCESSORY IF:

- You do not understand these installation and use instructions,
- You do not understand any part of the accessory mounting system,
- You have any doubts as to the security of the mounting system.

If you have any concerns or questions, contact your authorized MOOSE retailer.

Remember: Motorcycling can be a dangerous activity. Installation of any accessory can increase your risk if it is not installed properly. You are responsible to install this accessory so it will not contact any portion of the drive train, suspension or steering, and so that it will in no way interfere with the operation of your motorcycle.

RECOMMENDED TOOLS & MATERIALS:

10mm wrench or socket (need two)	8mm socket tool	Allen wrench set (includes 4 & 5mm hex tools)
Torque Wrench	Power drill (up to 1/2" chuck)	1/4" drill bit
Center punch	Deburring tool (or 1/2" drill bit)	Masking tape & pencil
Shop vacuum	Suggested: Double-sided adhesive tape	

NOTE: Other tools or hardware may be required, depending upon your vehicle, previously installed accessories, and how you will mount this accessory.

Continued on next page...

ITEMS INCLUDED WITH YOUR MOUNT KIT:

Motorcycle-specific parts	Qty.	Mounting plate-related parts	Qty.
Mounting tab (2" L)	4	Aluminum top case mount plate	1
Spacer (steel, 1/2" L)	4	Buffer/drill template	1
Collar (aluminum, 3/8" L)	4	Flange bolt (6 x 20mm)	4
Bolt, countersunk (6 x 65mm)	2	Nylock flange nut (6mm)	4
Bolt, countersunk (6 x 45mm)	2	Washer (1.25" dia)	4
Bolt, countersunk (6 x 10mm)	2	Rubber washer (1.5" dia)	4
Instruction sheet (not shown)	1		

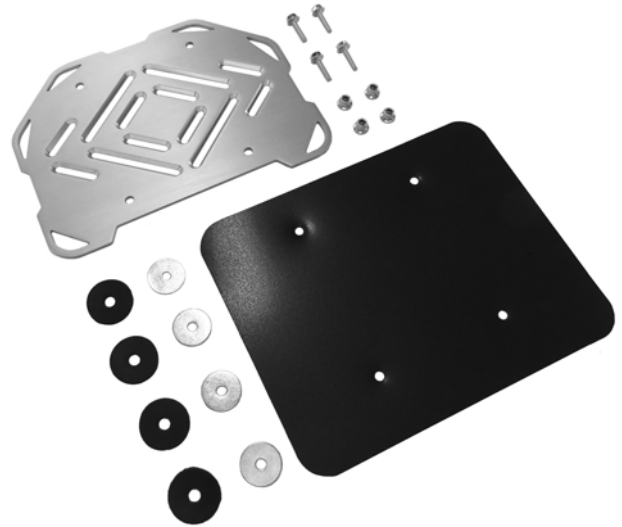

Appearance and scale of sample images may differ from actual supplied parts

INSTALLATION INSTRUCTIONS:

REMINDER - Do not attempt to mount your top case if you do not have the technical ability to do so. Seek out a qualified motorcycle technician if you need assistance mounting your top case. Enlist the aid of a helper when installing the top case and mount as a extra set of hands will help you avoid damaging your accessories. Save any removed hardware so you can return the motorcycle to its original configuration if you decide to remove the top case or its mount.

NOTE: The mounting system of your MOOSE top case uses arms that will pivot on spacers to align with a variety of slots machined into the aluminum mounting plate. This permits a wide range of mounting plate positions on the motorcycle. This instruction set recommends a plate position that permits tool kit access.

STEP 1: Remove the four 6mm bolts ① as indicated in the image to the right. Once the bolts are removed from the rack's plastic cover, set the supplied four aluminum collars ② into the cover.

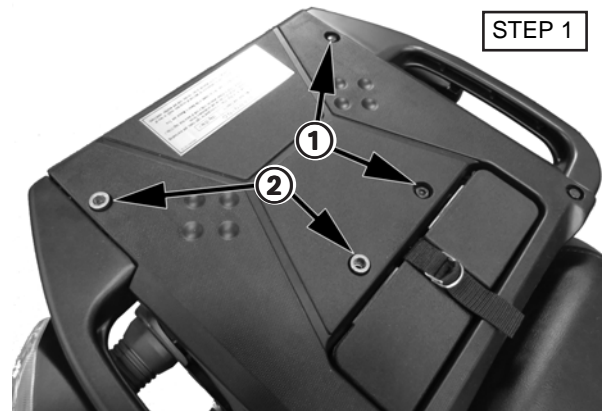

STEP 2: Set the four supplied 1/2" long spacers ③ on top of the collars you installed in STEP 1. Lightly thread the two supplied 6 x 65mm countersunk-head bolts ④ through the two of the supplied arms ⑤, and then through the spacer and collar into the front two thread holes as shown. Lightly thread the two supplied 6 x 45mm countersunk-head bolts ⑥ through the other two supplied arms, and then through the spacer and collar into the rear threaded holes as shown. Snug all of the hardware and position the arms like the image at right (you will fully tighten the hardware during STEPS 3 & 4).



WARNING: Always apply a thread-locking agent to the threads of the bolts and nuts as you install the mounting hardware. Do this to the new hardware and original fasteners you reinstall as part of the mount or top case installation procedure. Suggest the use of Three Bond Hi-Strength Thread Lock; obtain #TB-1303 or an equivalent from your MOOSE dealer.

Continued on next page...

STEP 3: The aluminum plate ① has been designed to accept countersunk, flat-head style 6 x 10mm bolts ②. These bolts fit flush into the slots that have been machined into the surface of the mounting plate.

Use the reference image at right to help you set the bolts in the slot locations that correspond to the arms you installed in STEP 2. Just lightly install the bolts and adjust the position of the plate on the rack so it is aligned properly on the motorcycle. Once you are pleased with the plate location, carefully remove the bolts so you can do the final tightening of the bolts that hold in the arms in place.

Recommended 6mm arm bolt torque: 7 - 10 ft-lb (1.0 - 1.4 kg-m)

Suggest the use of Three Bond Hi-Strength Thread Lock
(obtain #TB-1303 or an equivalent from your MOOSE dealer)

WARNING: Take care when tightening the 6mm arm bolts. The tightening process may cause the arms to rotate away from their ideal location. Enlist the aid of a helper so the arms can remain in position during tightening. If you fail to tighten the arm retention hardware to the proper torque, the rack could become loose on the motorcycle.

STEP 4: Place the aluminum plate back on the tightened arms and reinstall the four countersunk, flat-head style 6 x 10mm bolts ③. Tighten the bolts to the specified torque.

Recommended 6mm top bolt torque: 5 - 8 ft-lb (0.7 - 1.1 kg-m)

Suggest the use of Three Bond Hi-Strength Thread Lock
(obtain #TB-1303 or an equivalent from your MOOSE dealer)

NOTE: If you adjust the position of the aluminum plate and the mounting arms, verify that the arms do not interfere with the four mounting holes ④ that are in the plate for securing the top case to the mount.

STEP 5: You now must prepare your top case for mounting. Supplied with your mount kit is a plastic buffer/drill template sheet ⑤. This sheet has been engineered to mate perfectly with the bottom of the MOOSE Top Case. You will use the sheet to mark the location of the four holes ⑥ you will need to drill in to case to install the mounting hardware supplied in this kit. After the holes are drilled and cleaned, the plastic sheet is then attached to the top case via double-sided adhesive tape to help protect the case and the plate from abrasive wear.

NOTE: The hole pattern in the buffer/drill template is not symmetrical. One pair of holes are closer to the edge of the case so you can adjust the relationship of the case to the rack. If holes are drilled further away from the back of the case (the MOOSE emblem ⑦ is on the back of the case) the case will be rest further back on the mounting plate.

Set your top case down on a protected surface (with the lid removed) and position the buffer/template so it within the bumpers of the top case base. Use some masking tape ⑧ to temporarily hold the buffer/template in place for marking the drill hole locations.

STEP 6: Use a pencil to mark the center of the mounting holes in the case. Remove the buffer/template from the top case and use a center punch tool to create a pilot dent in the surface of the aluminum.

TIP: Avoid using a permanent marker or paint pen to mark the drill locations. This is so you can clean off a mark if needed. For dark color luggage, you can use light-colored masking tape that you can write on with a pencil (or use a white grease pencil). Apply the tape to the top case under the template.

CAUTION: Use a spring-loaded center punch tool to create the indentation. Avoid using a solid punch with a hammer or another method which could cause you to dent or scratch the surface of the top case.

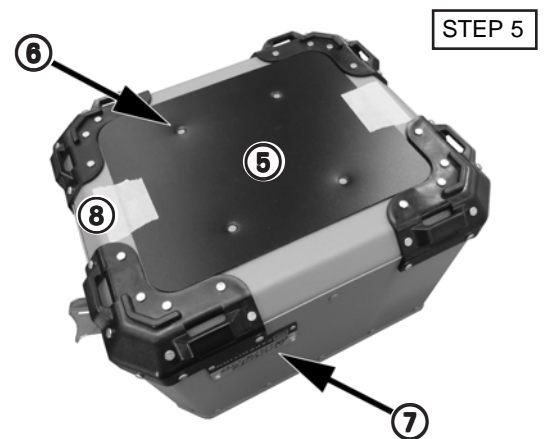

Continued on next page...

STEP 7: Use the 1/4" drill bit to carefully drill each of the required holes. Hand-turn a large drill bit (1/2") or use a formal deburring tool to remove any burrs or loose material from the drilled holes. After the holes are deburred, and the debris or masking tape is cleaned off the case, put the buffer/template back into place.



CAUTION: Deburr the exterior and interior of the holes. Use a shop vacuum to clean up the drilling debris from the inside of the case. Take care to keep your work area clean of aluminum chips or other debris that could damage the top case's finish.

TIP: If you will be removing and reinstalling your top case frequently, install some double sided tape between the bottom of the case and the plastic protector. This will ease mounting as it will prevent the protector from dropping off the case. Obtain the double-sided adhesive tape from your local hardware store.

STEP 8: Set the top case on the aluminum mounting plate and align the holes in the bottom of the case with the holes in the plate. Insert the 6 x 20mm flange bolt (1) through the 1.25" OD steel washer (2), and then through the 1.5" OD rubber washer (3). Finally insert the bolt/washers through the bottom of the case and through the holes in the aluminum mounting plate. Do the same for all four of the bolt holes.

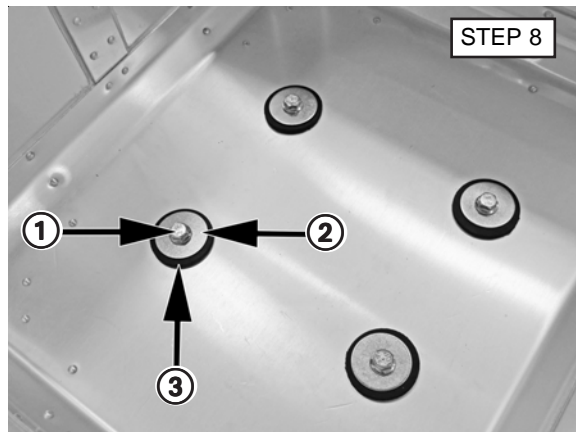

STEP 9: Install the 6mm flange nuts (4) on the bolt ends that protrude through the underside of the aluminum mounting plate. The nuts supplied with your mount set are a self-locking type. However, it is still recommend to use a locking agent on all bolt and nut threads. Tighten them to the specified torque.

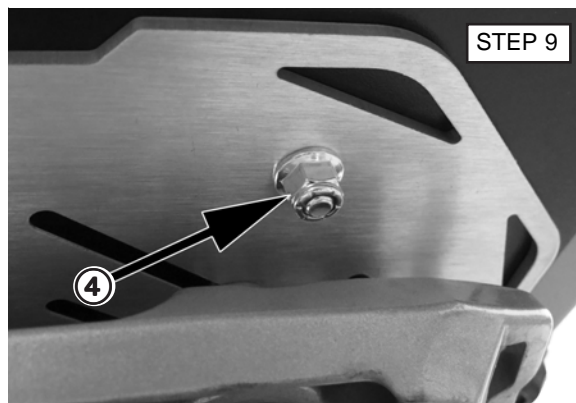

Recommended 6mm flange bolt & nut torque: 7 - 10 ft-lb (1.0 - 1.4 kg-m)

Suggest the use of Three Bond Hi-Strength Thread Lock
(obtain #TB-1303 or an equivalent from your MOOSE dealer)

NOTE: As the final step of the top case mount installation process, you must tighten all of the new hardware and any other related hardware on your motorcycle. These fasteners should be tightened to the torque values specified in your vehicle's Owner's and Service Manuals. Threads should be treated with a thread locking agent before installation.

5mm screw	3 - 4 ft-lb	(0.35 - 0.5 kg-m)
5mm bolt & nut	3 - 4 ft-lb	(0.35 - 0.5 kg-m)
6mm screw	5 - 8 ft-lb	(0.7 - 1.1 kg-m)
6mm bolt & nut	6 - 9 ft-lb	(0.8 - 1.2 kg-m)
8mm bolt & nut	13 - 18 ft-lb	(1.8 - 2.5 kg-m)
8mm flange bolt & nut	14 - 21 ft-lb	(2.0 - 3.0 kg-m)
10mm bolt & nut	22 - 29 ft-lb	(3.0 - 4.0 kg-m)
10mm flange bolt & nut	22 - 29 ft-lb	(3.0 - 4.0 kg-m)
12mm bolt & nut	36 - 43 ft-lb	(5.0 - 6.0 kg-m)

Continued on next page...

OPTIONAL ITEMS AVAILABLE: You can obtain a attachment kit which includes hardware that permits top case removal and installation without tools. See your MOOSE dealer to order part number 1510-0239.

CAUTION: Be sure to follow the instructions included with the optional quick-release kit. You must use hardware from your main mounting kit in addition with the threaded knob and other hardware supplied in the kit. When riding over rough paved roads, or unimproved terrain, or with a heavy cargo load you should always use the supplied, standard mounting bolts and locking nuts. This hardware will properly secure your top case to the mount during this type of use.

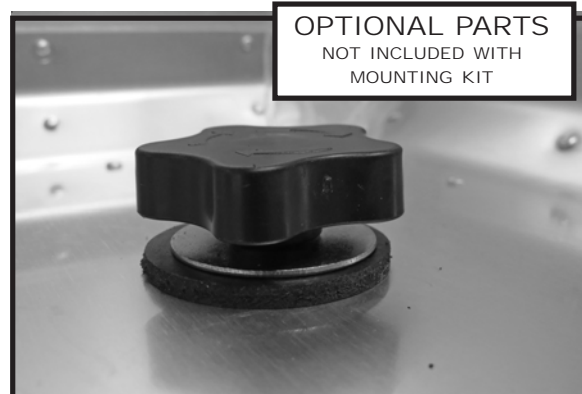

MAXIMUM LOAD CAPACITY: 15 lbs (6.8 kg)

While your top case mount has been designed to tolerate the rigors of touring use, care must be taken to not overload your luggage and your vehicle. Include the weight of the top case when calculating the amount of cargo you will be carrying on your motorcycle. Do not exceed your vehicle's Maximum Gross Vehicle Weight as listed on your motorcycle or in its Owner's Manual.

IMPORTANT:

Failure to install this accessory properly may allow portions of the mount, mounting hardware or top case to come into contact with the motorcycle's chassis, moving parts or controls. It is vital that you verify that the accessory will not touch, or interfere with, other motorcycle components while the steering or suspension moves through its entire range of motion. Make sure that the top case, its mount or any related hardware can come into contact with the exhaust or any other component of the motorcycle, as other vehicle components may be damaged by contact with this accessory.

It is your responsibility to make sure the installation of this accessory does not create an unsafe or illegal condition. Check to be sure that all lights and safety reflectors are visible once the top case is in place. If the top case blocks any side reflectors, place reflectors on the exterior sides of the panniers (reflectors with self-adhesive backing are available from motorcycle or automobile supply stores). After 50 miles (80 kilometers) of riding, recheck the top case and mount to make sure that they are still tight and secure. Inspect the accessories more often if you are riding your motorcycle in wet or rough conditions (such as a dirt road). Inspect the accessory and related hardware before and during each ride. Loose accessory and/or mounting hardware can interfere with the vehicle's operation and cause an unsafe riding condition.

CARE OF YOUR MOOSE EXPEDITION TOP CASE MOUNT:

Check the attachment and assembly hardware often; tighten these fasteners as recommended in this instruction set and as listed in your vehicle's owner's manual. Your MOOSE mount requires almost no cosmetic maintenance, other than periodic cleaning with mild soap and water. It is normal for some scuffing of the mount's finish to occur, especially if you operate your motorcycle in dusty, wet or dirty conditions. This type of wear is normal and is not considered a defect, so repair or replacement of parts due to this type of surface wear is not covered under the product's limited warranty. You can use clear paint to cover such wear so the metal does not corrode.

MOOSE LIMITED ONE-YEAR WARRANTY

Moose warrants this product for defects in materials, design or workmanship for a period of one year after retail purchase. Items that are defective will be repaired or replaced by MOOSE at its sole discretion. Damage caused by improper use or improper installation is not a defect; therefore repair or replacement of a damaged accessory will not be covered under this warranty. This warranty contains other provisions and conditions, so please visit www.mooseracing.com for additional information. Thank you for purchasing your MOOSE Expedition Top Case Mount. You can count on MOOSE's quality, innovation, service and style. We want you to be completely satisfied. If you have any comments, or are not satisfied with the performance of your accessory, please contact your MOOSE retailer directly.