



Part #	Qty.	Description
2202-70	1	Training Wheel Rod
PC514	2	Wheels
HDW1041	2	8mm Nylock Nuts
HDW1062	2	8mm x 60mm Hex Bolts
HDW2300	2	1/8" x 1-1/2" Cotter Pins
HDW9006	2	5/8" Fender Washers

## TRAINING WHEEL MOUNTING INSTRUCTIONS

**CUSTOMER MUST RECEIVE A COPY OF THIS INSTRUCTION SHEET AT THE TIME OF SALE**

1. Place washer on training wheel rod and install cotter pin for wheel assembly as per illustration.  
**Note: Make sure the valve stem on the tire is facing toward the machine.**
2. Remove stock pin from foot peg, being careful not to remove peg spring when pulling out pin.
3. Place training wheel assembly to foot peg per illustration and insert bolt provided.
4. Repeat on other side.

**NOTE: Check the operation of the rear brake before riding the bike. If out of adjustment the rear brake lever may contact the training wheel shaft before engaging the brake. Adjust as necessary until the brake works properly.**

## Yamaha PW50

P/N: 9501-00129

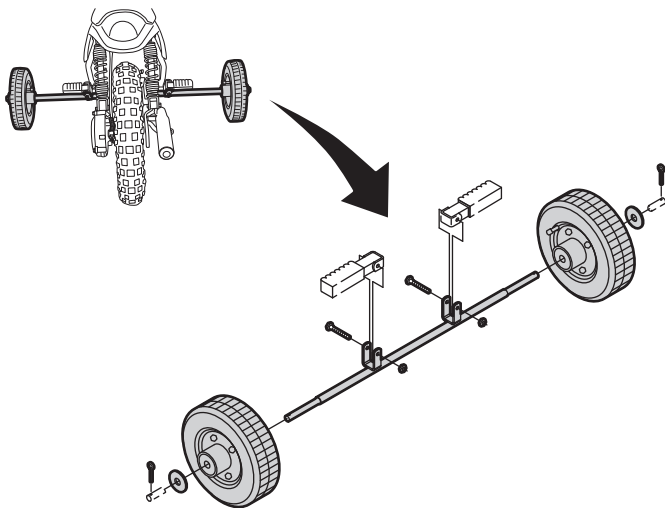

## Kawasaki KDX50 Suzuki JR50

P/N: 9501-0126

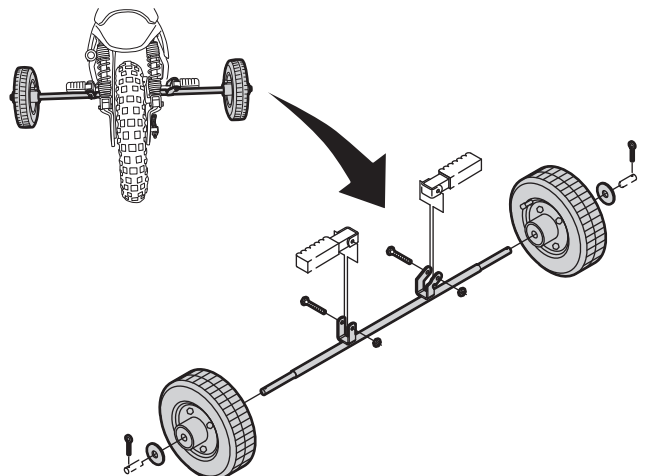

FOR QUESTIONS REGARDING YOUR ORDER OR RETURNS CONTACT THE COMPANY YOU PURCHASED FROM.  
FOR TECHNICAL OR INSTALLATION QUESTIONS PLEASE CALL: 763-689-4800